

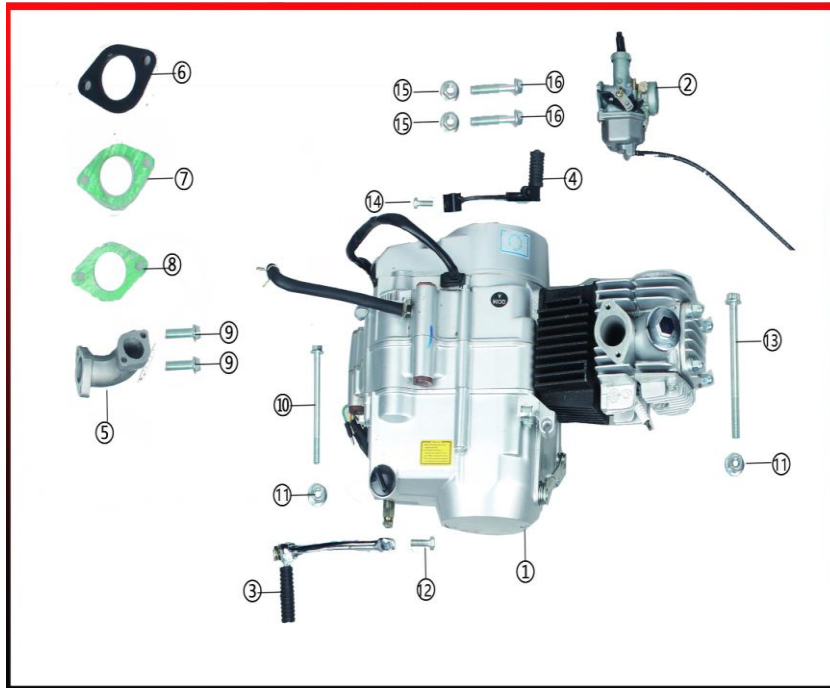

1、Suspension System					
NO.	ICEBEAR PART NO.	FACTORY PART NO.	CHINESE NAME	English Name	QTY
①	PAD125-3-A-001	10101010020	左前减震器	Up-side-down front suspensio	1
②	PAD125-3-A-002	10101010030	右前减震器	Up-side-down front suspensio	1
③	PAD125-3-A-003	10801020000	后减震器	Rear shock	1
④	PAD125-3-A-004	GB5787M104501	六角法兰面螺栓	Bolt, flanged	1
⑤	PAD125-3-A-005	B5787M10105501	六角法兰面螺栓	Bolt, flanged	1
⑥	PAD125-3-A-006	GBT6187M101201	六角法兰面锁紧螺母	Nut, flanged locking	2
⑦	PAD125-3-A-007	10101010040	前减震左右护板	Front Fork Protector	1
⑧	PAD125-3-A-008	GB/T818-85	护板螺丝	Protector bolt	6



2、Engine System

NO.	ICEBEAR PART NO.	FACTORY PART NO.	CHINESE NAME	English Name	QTY
①	PAD125-3-B-001	10802010000	发动机总成	Engine assembly	1
②	PAD125-3-B-002	10802020000	化油器	Carburetor	1
③	PAD125-3-B-003	10802040000	启动杆	Kick start	1
④	PAD125-3-B-004	10802030000	变档杆	Gear shift	1
⑤	PAD125-3-B-005	10802010010	进气管	intake manifold	1
⑥	PAD125-3-B-006	10802010020	隔热垫, 上下密封纸垫	Insulation mat, Upper&Down se	1
⑨	PAD125-3-B-007	GB5787M62001	六角法兰面螺栓	Bolt flanged	2
⑩	PAD125-3-B-008	GB5787M810501	六角法兰面螺栓	Bolt flanged	1
⑪	PAD125-3-B-009	GBT6187M801	六角法兰面锁紧螺母	Nut, flanged locking	2
⑫	PAD125-3-B-010	GBT5782M62301	六角头螺栓	Bolt	1
⑬	PAD125-3-B-011	GB5787M811501	六角法兰面螺栓	Bolt flanged	1
⑭	PAD125-3-B-012	GBT5782M62001	六角头螺栓	Bolt	1
⑮	PAD125-3-B-013	GBT6177M601	六角法兰面自锁螺母	Nut, flanged locking	2
⑯	PAD125-3-B-014	GB5787M62801	六角法兰面螺栓	Bolt flanged	2

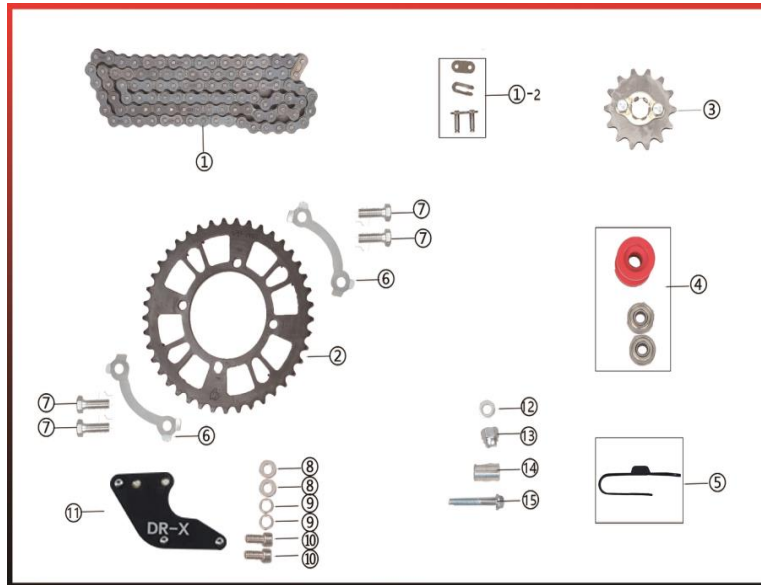

3、Transmission System

NO.	ICEBEAR PART NO.	FACTORY PART NO.	CHINESE NAME	English Name	QTY
①	PAD125-3-C-001	10103070010	链条总成	Chain assembly	1
①-2	PAD125-3-C-002	10803070200	连接片, 卡扣, 连接座	Connctor	1
②	PAD125-3-C-003	10803010000	后链轮	Rear sprocket	1
③	PAD125-3-C-004	10803030000	小链轮组件	Minor sprocket assembly	1
④	PAD125-3-C-005	10803040000	导链轮, 轴承	Chain roller assy	1
⑤	PAD125-3-C-006	10803040020	导链套	chain plate guide	1
⑥	PAD125-3-C-007	10803010010	链轮锁片	Sprocket lock plates	2
⑦	PAD125-3-C-008	GBT5782M82501	六角头螺栓	Bolt	4
⑧	PAD125-3-C-009	GBT97.1801	平垫圈	Flat washer	2
⑨	PAD125-3-C-010	GBT93801	弹垫圈	Lock washer	2
⑩	PAD125-3-C-011	GBT70.1M82001	内六角螺栓	Bolt	2
⑪	PAD125-3-C-012	10103060000	挡链器	Chain guide	1
⑫	PAD125-3-C-013	10803040030	隔套	Spacer	1
⑬	PAD125-3-C-014	GB/T 923M8	球头螺母	Nut	1
⑭	PAD125-3-C-015	15603040100	导链轮衬套	Chain roller spacer	1
⑮	PAD125-3-C-016	GB5787M85501	六角法兰面螺栓	Bolt flanged	1

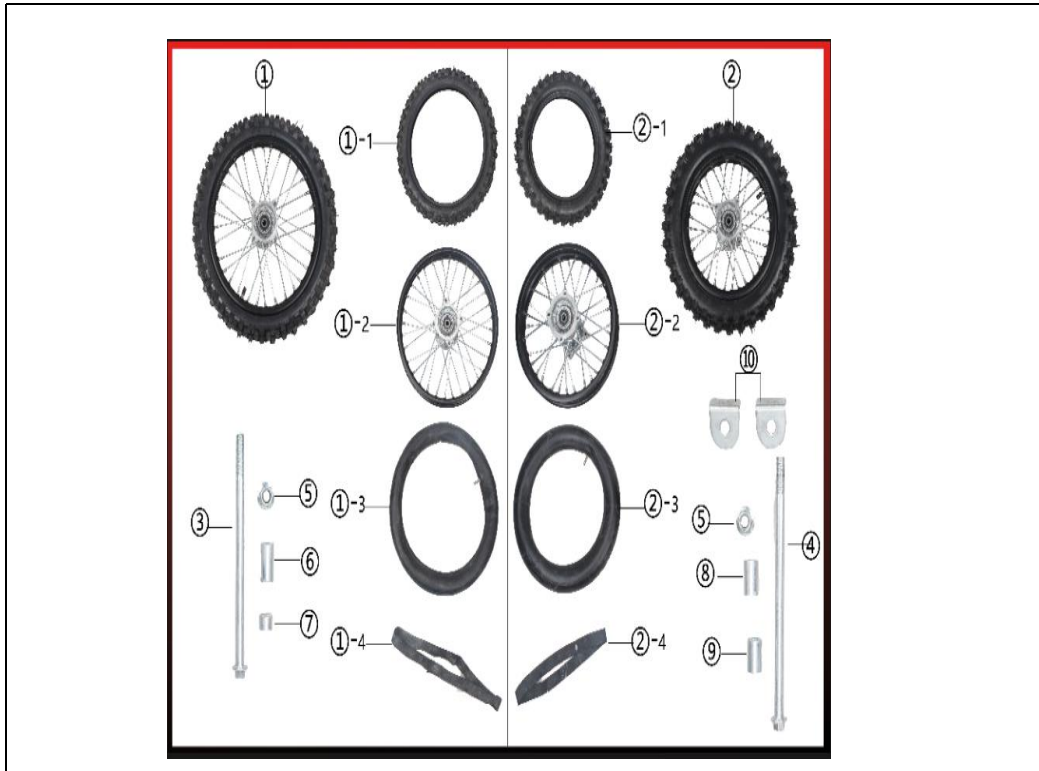

3、Transmission System Assembly

NO.	ICEBEAR PART NO.	FACTORY PART NO.	CHINESE NAME	English Name	QTY
①	PAD125-3-D-001	10803080000	前轮辋总成	Rim assy front	1
①-1	PAD125-3-D-002	10803080010	前轮外胎	Front tire	1
①-2	PAD125-3-D-003	10803080020	前轮辋	Front rim	1
①-3	PAD125-3-D-004	10803080030	前轮内胎	Front inner tube	1
①-4	PAD125-3-D-005	10803080040	衬带	Protector band	1
②	PAD125-3-D-006	10803090000	后轮辋总成	Rim assy. rear	1
②-1	PAD125-3-D-007	10803090010	后轮外胎	Rear tire	1
②-2	PAD125-3-D-008	10803090020	后轮辋	Rear rim	1
②-3	PAD125-3-D-009	10803090030	后轮内胎	Front inner tube	1
②-4	PAD125-3-D-010	10803090040	衬带	Protector band	1
③	PAD125-3-D-011	10103100000	前轮轴	Front axle	1
④	PAD125-3-D-012	10103100030	后轮轴	Rear axle	1
⑤	PAD125-3-D-013	GBT6187M1501	六角法兰面锁紧螺母	Nut flanged locking	2
⑥	PAD125-3-D-014	10103100010	前轮左轴套	Front axle spacer LH	1
⑦	PAD125-3-D-015	10103100020	前轮右轴套	Front axle spacer RH	1
⑧	PAD125-3-D-016	10103100040	后轮左轴套	Rear axle spacer LH	1
⑨	PAD125-3-D-017	10103100050	后轮右轴套	Rear axle spacer RH	1
⑩	PAD125-3-D-018	10103100060	调链片	Chain adjuster	2

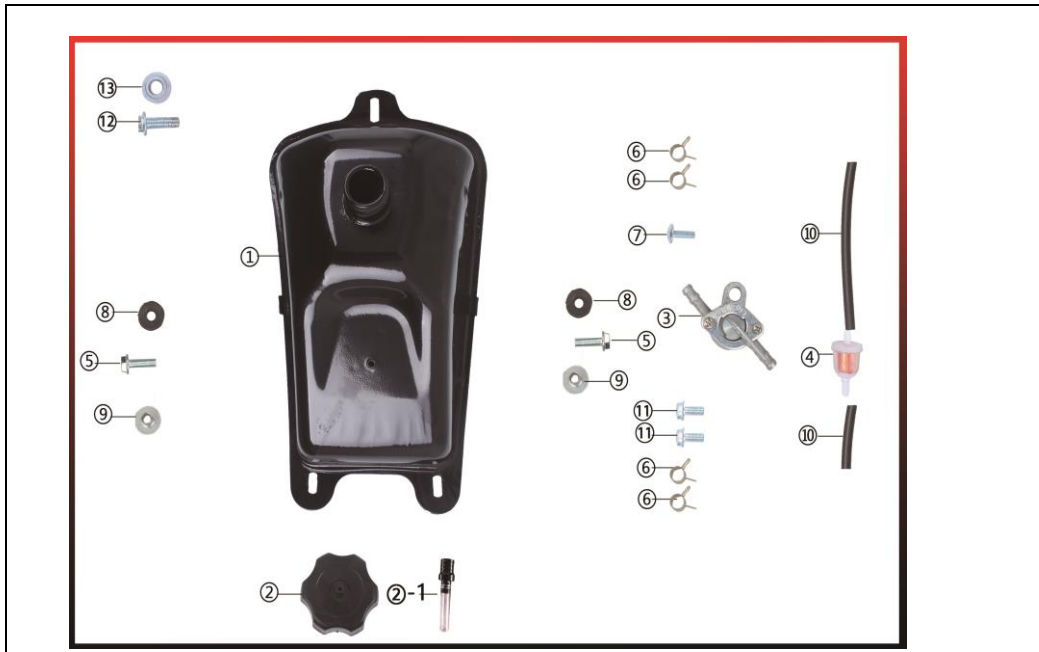

4、 Fuel Supply System

NO.	ICEBEAR PART NO.	FACTORY PART NO.	CHINESE NAME	English Name	QTY
①	PAD125-3-E-001	10104010010	油箱	Fuel tank, Iron	1
②	PAD125-3-E-002	10104020000	油箱盖	Fuel tank cap	1
②-1	PAD125-3-E-003	10104040030	通气阀	Breather	1
③	PAD125-3-E-004	10804030000	油箱开关	Tank switch	1
④	PAD125-3-E-005	10804060000	汽油过滤器	Fuel filter	2
⑤	PAD125-3-E-006	GB5787M62001	六角法兰面螺栓	Bolt flanged	2
⑥	PAD125-3-E-007	10804040040	油管卡箍	Fuel hose clamp	6
⑦	PAD125-3-E-008	GBT70. 1M61601	内六角螺栓	Bolt	1
⑧	PAD125-3-E-009	10104010040	油箱胶圈	Rubber washer	3
⑨	PAD125-3-E-010	10804010030	T型套	T-flanged spacer	2
⑩-1	PAD125-3-E-011	10804040000	油管1	Fuel hose 1	1
⑩-2	PAD125-3-E-012	10804040010	油管2	Fuel hose 2	1
⑪	PAD125-3-E-013	GB5787M62001	六角法兰面螺栓	Bolt flanged	1
⑬	PAD125-3-E-014	GB/T6177	六角法兰面螺母	Nut flanged	1
⑫	PAD125-3-E-015	GB5787M82501	六角法兰面螺栓	Bolt flanged	1

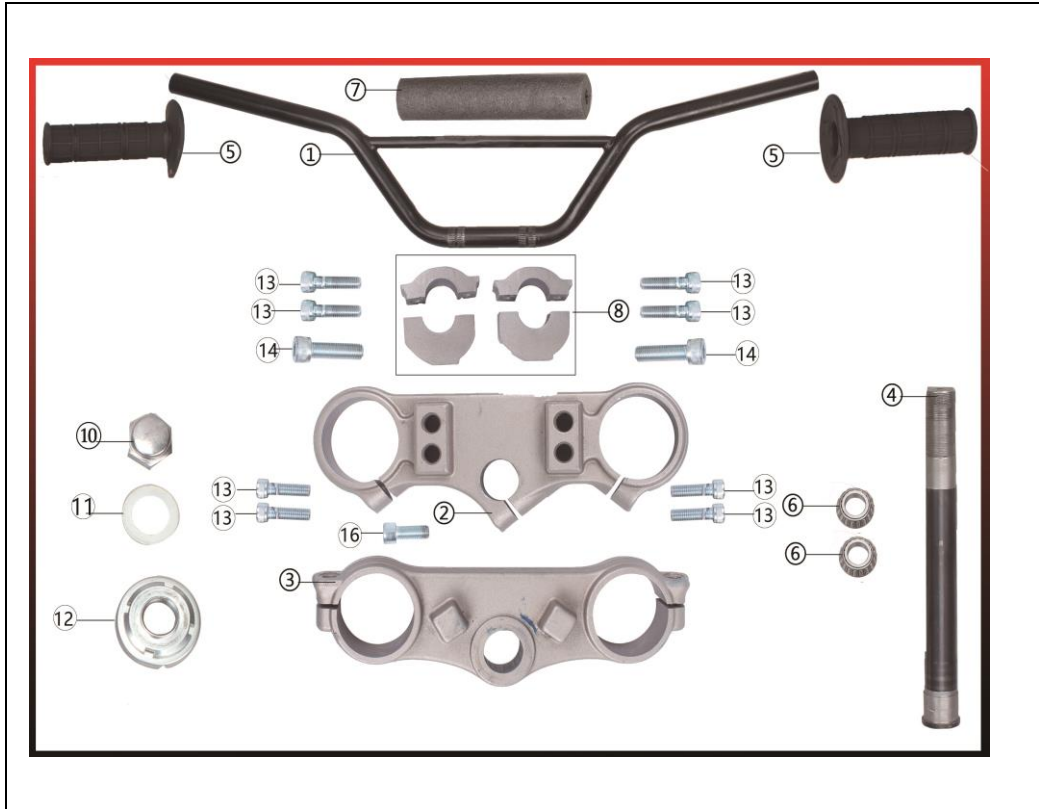

5、Steering System

NO.	ICEBEAR PART NO.	FACTORY PART NO.	CHINESE NAME	English Name	QTY
①	PAD125-3-F-001	10805010000	方向把	Handle bar	1
②	PAD125-3-F-002	10105060000	上连板	Top triple clamp	1
③	PAD125-3-F-003	10105060010	下联板	Bottom triple clamp	1
④	PAD125-3-F-004	10105060080	方向柱	Steering stem	1
⑤	PAD125-3-F-005	10805040000	左右把套	left & right hand grip	1
⑥	PAD125-3-F-006	10805060040	滚针轴承总成	Top needle bearing assy	1
⑦	PAD125-3-F-007	10805030000	方向把护胸	Foam padding	1
⑧	PAD125-3-F-008	10105060020	联板上下压块	Top & Bottom handle bar riser	2
⑩	PAD125-3-F-009	10805060050	盖母	Steering stem top nut	1
⑪	PAD125-3-F-010	10805060060	大平垫	Flat washer	1
⑫	PAD125-3-F-011	10805060070	锁母	lock nut	1
⑬	PAD125-3-F-012	GBT70. 1M82501	内六角螺栓	Bolt	8
⑭	PAD125-3-F-013	GBT70. 1M102501	内六角螺栓	Bolt	2
⑯	PAD125-3-F-014	GBT70. 1M82001	内六角螺栓	Bolt	1

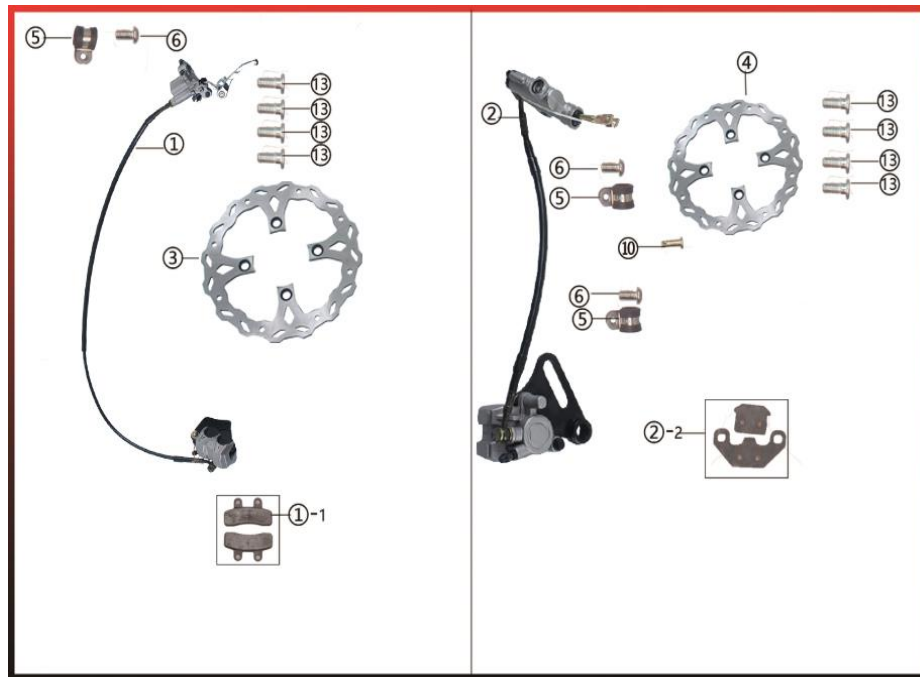

6、Braking System

NO.	ICEBEAR PART NO.	FACTORY PART NO.	CHINESE NAME	English Name	QTY
①	PAD125-3-G-001	10106010010	前碟刹总成	Brake assy with brake front	1
①-1	PAD125-3-G-002	10806010020	前碟刹蹄块总成	Brake pad assy front	1
②	PAD125-3-G-003	10106010040	后碟刹总成	Brake assy with brake rear	1
②-2	PAD125-3-G-004	10806010050	后碟刹蹄块总成	Brake pad assy rear	1
③	PAD125-3-G-005	10806010060	前碟刹盘	Front brake disc	1
④	PAD125-3-G-006	10806010070	后碟刹盘	Rear brake disc	1
⑤	PAD125-3-G-007	10806010080	油管卡	Clamp hose	3
⑥	PAD125-3-G-008	GBT70. 1M61201	内六角盘头螺栓	Bolt	3
⑩	PAD125-3-G-009	GB/T6177	六角法兰面螺母	Nut flanged	1
⑬	PAD125-3-G-010	10806010100	碟刹盘固定螺栓	Bolt	4

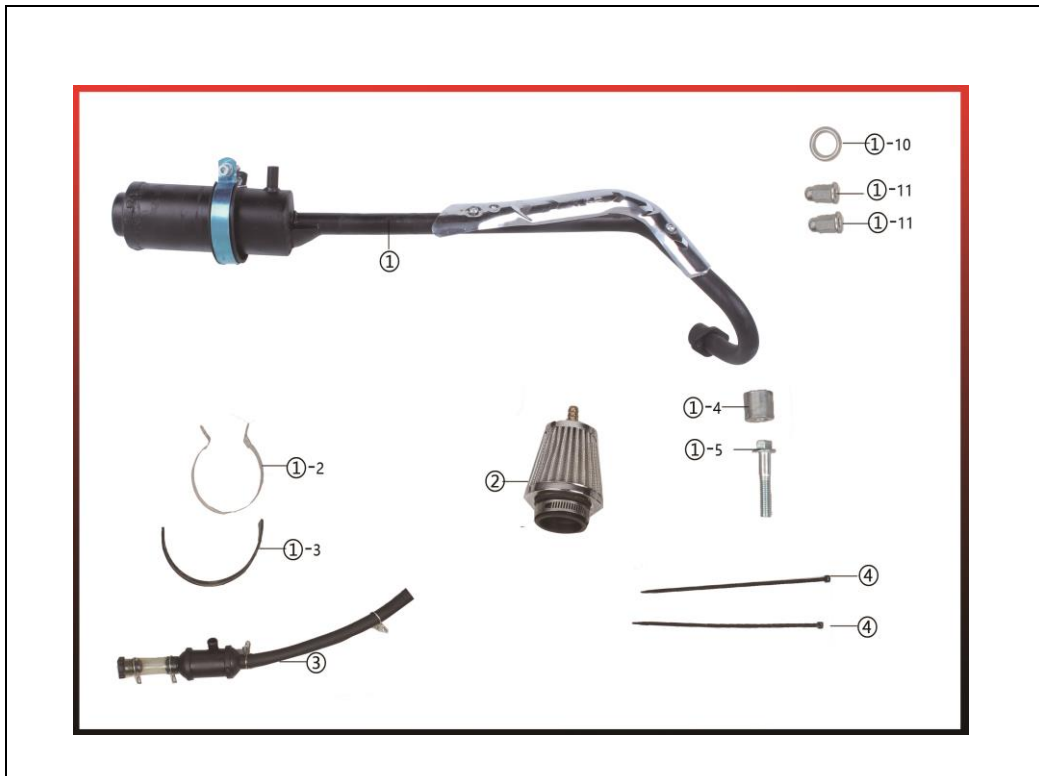

7、Intake & Exhaust System

NO.	ICEBEAR PART NO.	FACTORY PART NO.	CHINESE NAME	English Name	QTY
①	PAD125-3-H-001	10107010010	消音器总成	Exhaust assy	1
①-2	PAD125-3-H-002	10807010020	消音器卡箍	Exhaust Clamp	1
①-3	PAD125-3-H-003	10807010030	消音器卡箍橡胶垫	Breaker strip	1
①-4	PAD125-3-H-004	10807010050	隔套	Spacer	1
①-5	PAD125-3-H-005	GB5787M84001	六角法兰面螺栓	Bolt flanged	1
①-10	PAD125-3-H-006	10807010060	密封垫	Seal exhaust	1
①-11	PAD125-3-H-007	GBT923M601	高帽螺母	Muffler screws	2
②	PAD125-3-H-008	10807020000	空滤器	Air filter	1
③	PAD125-3-H-009	10807010040	二次补气装置	Second reflation	1
④	PAD125-3-H-010	10807010070	扎带	Strapping tape	2

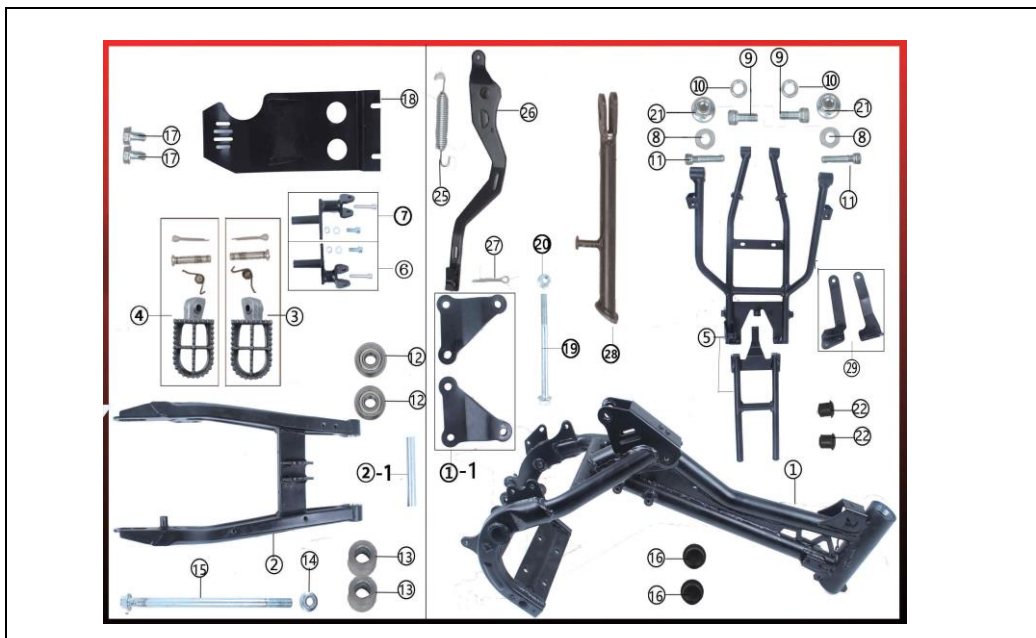

8、Frame & Accessories

NO.	ICEBEAR PART NO.	FACTORY PART NO.	CHINESE NAME	English Name	QTY
①	PAD125-3-I-001	10108010010	主车架	Frame	1
②	PAD125-3-I-002	10108020010	后平叉	Swing arm	1
③	PAD125-3-I-003	10808030000	左脚踏	Foot peg left	1
④	PAD125-3-I-004	10808030010	右脚踏	Foot peg right	1
⑤	PAD125-3-I-005	10108010030	后浮梁	Tail beam	1
①-1	PAD125-3-I-006	10108010040	发动机吊片	Engine mount bracket	1
②-1	PAD125-3-I-007	10108020050	平叉轴套	Swing arm Axle sleeve	1
⑥	PAD125-3-I-008	10108030030	左脚踏支架	Left Footrest support	1
⑦	PAD125-3-I-009	10108030040	右脚踏支架	Right Footrest support	1
⑧	PAD125-3-I-010	GBT97.1M801	平垫圈	Flat washer	6
⑨	PAD125-3-I-011	GBT70.1M84001	内六角螺栓	Bolt	2
⑩	PAD125-3-I-012	GBT93M801	弹垫圈	Lock washer	6
⑪	PAD125-3-I-013	GBT70.1M82001	内六角螺栓	Bolt	6
⑫	PAD125-3-I-014	6200ZZ/12	轴承	Bearing	2
⑭	PAD125-3-I-015	GBT6187M1201	六角法兰面锁紧螺母	Nut flanged locking	1
⑮	PAD125-3-I-016	10108020020	平叉轴	Swingarm axle	1
⑯	PAD125-3-I-017	10108020030	平叉防尘盖	Swingarm dustproof	2
⑰	PAD125-3-I-018	GB578701	六角法兰面螺栓	Bolt flanged	2
⑱	PAD125-3-I-019	10108010130	发动机护板	Engine plate cover	1
⑲	PAD125-3-I-020	GB5787M8	六角法兰面螺栓	Bolt flanged	
⑳	PAD125-3-I-021	GBT6187M8	六角法兰面锁紧螺母	Nut flanged	
㉑	PAD125-3-I-022	GBT6187M801	六角法兰面锁紧螺母	Nut flanged locking	2
㉒	PAD125-3-I-023	10808010060	后浮梁胶塞	Tail beam rubber plug	2
㉓	PAD125-3-I-024	10808010070	刹车踏板回位簧	Main kick stand spring	1
㉔	PAD125-3-I-025	10808010080	刹车踏板	Brake pedal	1
㉕	PAD125-3-I-026	GB/T 91-2000	开口销	Cotter pin	1
㉖	PAD125-3-I-027	10808010100	单撑	Single Stand	1
㉗	PAD125-3-I-028	10808010110	左右护板支架	LH & RH Fairing plate suport	

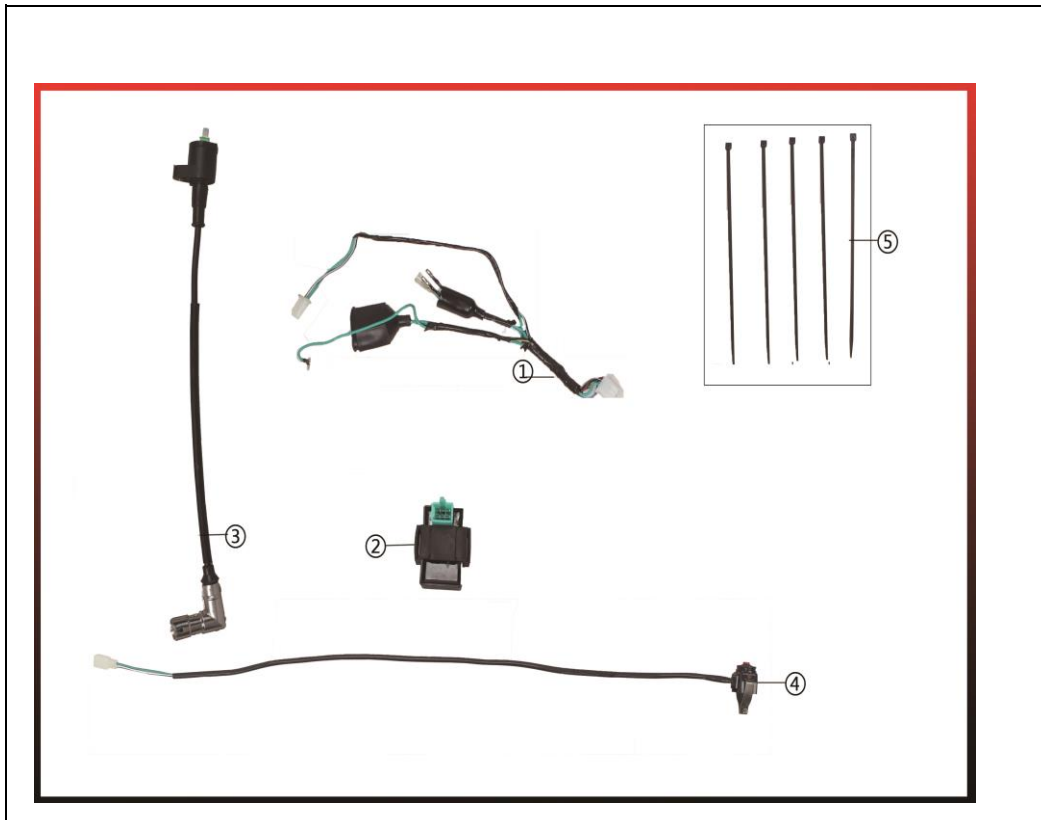

9、Electric System

NO.	ICEBEAR PART NO.	FACTORY PART NO.	CHINESE NAME	English Name	QTY
①	PAD125-3-J-001	10809010000	主电缆	Wiring harness	1
②	PAD125-3-J-002	10809020000	点火器	CDI assembly	1
③	PAD125-3-J-003	10809030000	点火线圈	Ignition coil assembly	1
④	PAD125-3-J-004	10809040000	熄火开关总成	Kill switch assembly	1
⑤	PAD125-3-J-005	10807010070	扎带	Strapping tape	5

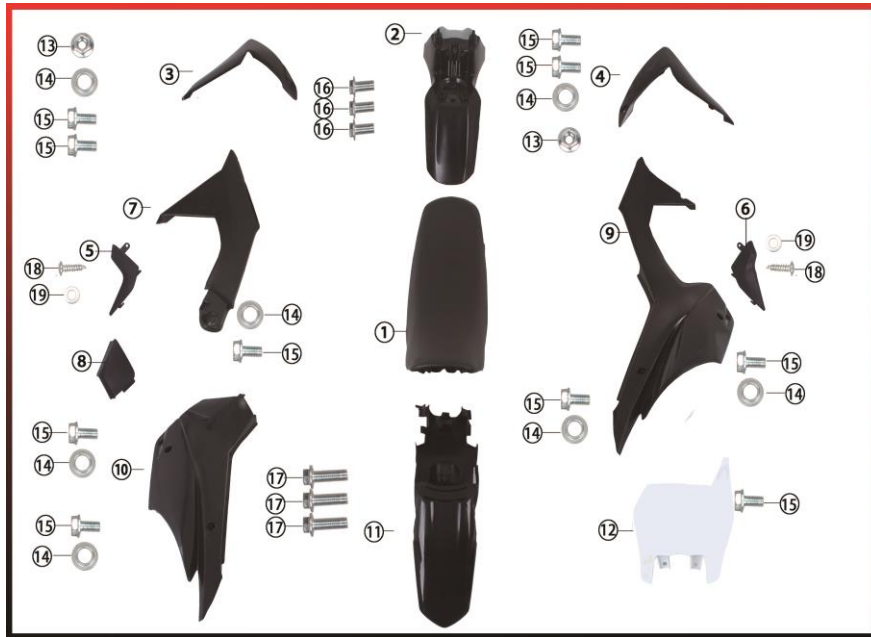

10、Covering Parts

NO.	ICEBEAR PART NO.	FACTORY PART NO.	CHINESE NAME	English Name	QTY
①	PAD125-3-K-001	10110020010	坐垫	Seat	1
②	PAD125-3-K-002	10110010010	前泥板	Front fender	1
③	PAD125-3-K-003	10110010030	左前护板	Fairing fuel tank LH	1
④	PAD125-3-K-004	10110010050	右前护板	Fairing fuel tank RH	1
⑤	PAD125-3-K-005	10110010150	左中护板卡件	Fairing fuel tank Clip LH Middle	1
⑥	PAD125-3-K-006	10110010160	右后护板卡件	Fairing fuel tank Clip RH Rear	1
⑦	PAD125-3-K-007	10110010120	左中护板	Fairing fuel tank LH Middle	1
⑧	PAD125-3-K-008	10110010170	左后护板卡件	Fairing fuel tank Clip LH Rear	1
⑨	PAD125-3-K-009	10110010090	右后护板	Fairing fuel tank RH	9
⑩	PAD125-3-K-010	10110010060	左后护板	Fairing fuel tank LH	8
⑪	PAD125-3-K-011	10110010110	后尾板	Rear Tail fender	4
⑫	PAD125-3-K-012	10110010140	前面板	Front plate	1
⑬	PAD125-3-K-013	GB/T6177	六角法兰面螺母	Nut flanged	2
⑭	PAD125-3-K-014	10810010180	T型套	T-flanged spacer	7
⑮	PAD125-3-K-015	GB/5787	六角法兰面螺栓	Bolt flanged	10
⑯	PAD125-3-K-016	GB/5787	六角法兰面螺栓	Bolt flanged	3
⑰	PAD125-3-K-017	GB/5787	六角法兰面螺栓	Bolt flanged	3
⑱	PAD125-3-K-018	GB/T845	自攻螺钉	Tapping screw	2
⑲	PAD125-3-K-019	GB/T 97.1	平垫圈	Flat washer	2

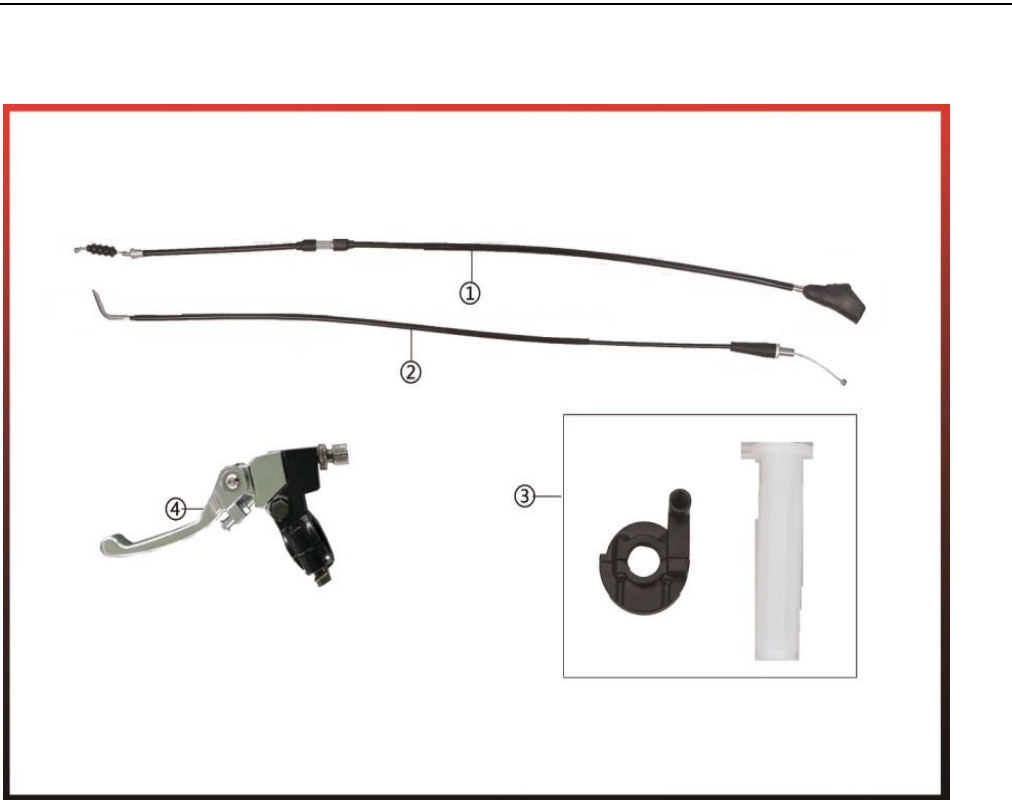

11、Operation System

NO.	ICEBEAR PART NO.	FACTORY PART NO.	CHINESE NAME	English Name	QTY
①	PAD125-3-L-001	10111020020	离合线	Clutch cable	1
②	PAD125-3-L-002	10111010020	油门线	Throttle cable	1
③	PAD125-3-L-003	15611010000	油门转把	Throttle base	1
④	PAD125-3-L-004	15611020000	离合手把	Clutch levers	1

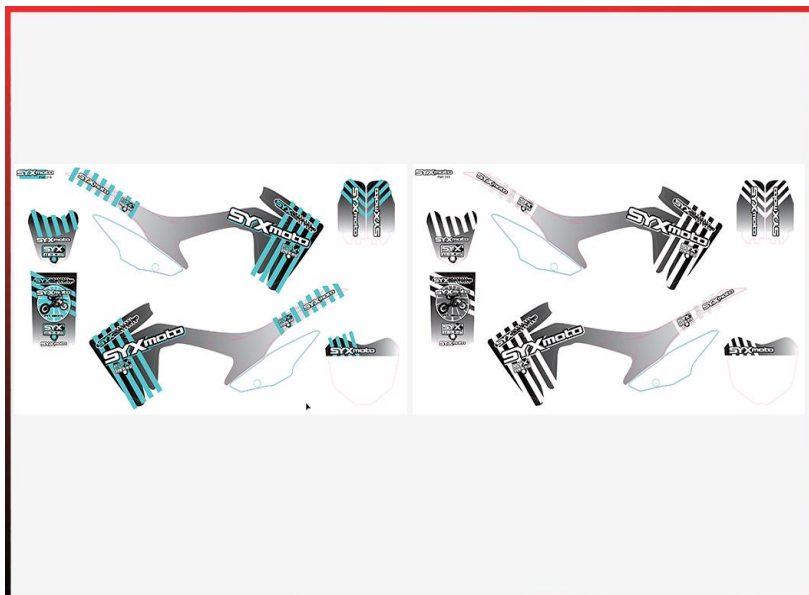

12、Decals Kits

图号 Item No.	ERP 配件编号	中文名称 Chinese name	英文名称 English name	单车数量 Unit	
①	PAD125-3-M-001	15611030100	V-ONE125 蓝色 全套贴花	V-ONE125 BLUE decals kits	1
②	PAD125-3-M-002	15611030101	V-ONE125 黑色 全套贴花	V-ONE125 BLACK decals kits	1

NO.	ICEBEAR PART NO.	FACTORY PART NO.	CHINESE NAME	English Name	QTY
1	PAD125-3-E-A-001	2067A038PW	气缸体/铸铁缸	CYLINDER BODY	1
2	PAD125-3-E-A-002	206B010	气缸体密封垫	CYLINDER BODY SEAL PACKIN	1
3	PAD125-3-E-A-003	215A000	气缸头组件/带内部附件	CYLINDER HEAD ASSY	1
	PAD125-3-E-A-004	215A000PW	气缸头组件/光缸头	CYLINDER HEAD ONLY	
6	PAD125-3-E-A-005	206B008	气缸头密封垫组件	CYLINDER HEAD SEAL GASKET	1
7	PAD125-3-E-A-006	97108012	定位销 8×12	ASSEMBLING PIN 8×12	4
12	PAD125-3-E-A-007	D00C031	矩形密封圈	RECTANGLE SEAL PING	1
13	PAD125-3-E-A-008	D00L033	矩形密封圈	RECTANGLE SEAL PING	1

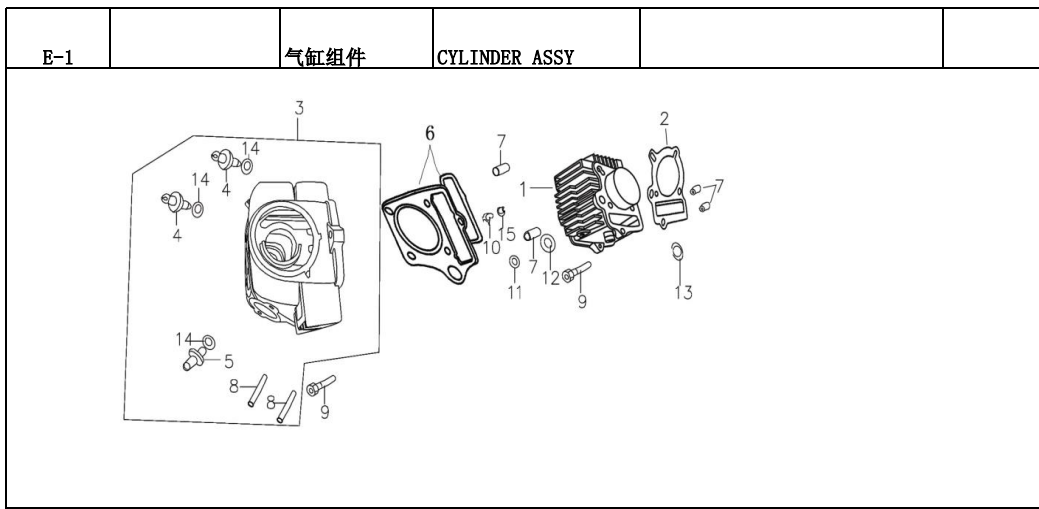

NO.	ICEBEAR PART NO.	FACTORY PART NO.	CHINESE NAME	English Name	QTY
1	PAD125-3-E-B-001	206A036PW	气缸头盖	CYLINDER HEAD COVER	1
2	PAD125-3-E-B-002	206B009	气缸头盖密封垫	CYLINDER HEAD COVER SEAL	1
3	PAD125-3-E-B-003	E03A033PW	气缸头左盖/镀铬	CYLINDER HEAD LEFT COVER	1
4	PAD125-3-E-B-004	E03B006	气缸头左盖密封圈	CYLINDER HEAD LEFT COVER S	1
5	PAD125-3-E-B-005	E03A035PW	气缸头右盖	CYLINDER HEAD RIGHT COVER	1
6	PAD125-3-E-B-006	D00B007	气缸头右盖密封圈	CYLINDER HEAD RIGHT COVER	1
7	PAD125-3-E-B-007	215A032PW	气门盖/镀铬	VALVE COVER	2
8	PAD125-3-E-B-008	D001C058	气门盖密封圈	SEAL FOR INTAKE VALVE	2
11	PAD125-3-E-B-009	D00D021	NGK普通火花塞不带电阻	NGK/SPARK PLUG	1
12	PAD125-3-E-B-010	E03L016	垫圈	CUSHION RING	3
13	PAD125-3-E-B-011	E03L156	垫圈	CUSHION RING	1
14	PAD125-3-E-B-012	923070000LBX	螺母	NUT	4
15	PAD125-3-E-B-013	GB578701	螺栓	BOLT	1
16	PAD125-3-E-B-014	GB7001	内六角螺栓	SCREW	4

E-2		气缸头	CYLINDER HEAD		
NO.	ICEBEAR PART NO.	FACTORY PART NO.	CHINESE NAME	English Name	QTY
17	PAD125-3-E-C-001	96006016LBX	带盘螺栓	PLATE BOLT	6
18	PAD125-3-E-C-002	D001B014	进气管密封垫	SEAL PACKING FOR THE INTAKE	1
19	PAD125-3-E-C-003	L00JQ214PW	进气管/YX02	INTAKE	1
20	PAD125-3-E-C-004	204B030	密封垫	SEAL PACKING	1
21	PAD125-3-E-C-005	204C039	隔热垫	CARBURETOR SEAL PACKING	1
22	PAD125-3-E-C-006	96006025LBX	带盘螺栓	PLATE BOLT	4

NO.	ICEBEAR PART NO.	FACTORY PART NO.	CHINESE NAME	English Name	QTY
1	PAD125-3-E-D-001	D00F013	单向器锁止板组合	ISOLATOR LOCKER ASSEMBLY	1
2	PAD125-3-E-D-002	D001F020	凸轮轴组件	CAMSHAFT SUBASSEMBLY	1
3	PAD125-3-E-D-003	D00F015	进气摇臂轴	AIR-IN ROCKERARM SHAFT	1
5	PAD125-3-E-D-004	D00F015	摇臂轴	ROCKERARM SHAFT	1
6	PAD125-3-E-D-005	D00F000	气门摇臂	ROCKER ARM, VALVE	2
9	PAD125-3-E-D-006	D00F034	气门内外弹簧座	UP SPRING SEAT	2
10	PAD125-3-E-D-007	D00F033	气门锁夹	AIR VALVE LOCKER	2
11	PAD125-3-E-D-008	D00H004	气门内弹簧	INNER SPRING, VALVE	2
12	PAD125-3-E-D-009	D00H003	气门外弹簧	OUTER SPRING, VALVE	2
14	PAD125-3-E-D-010	204F045	进气门	INDUCTION VALVE	1
15	PAD125-3-E-D-011	204F039	排气门	EXHAUST VALVE	1
16	PAD125-3-E-D-012	D00C043	油封	VALVE STEM SEAL	2

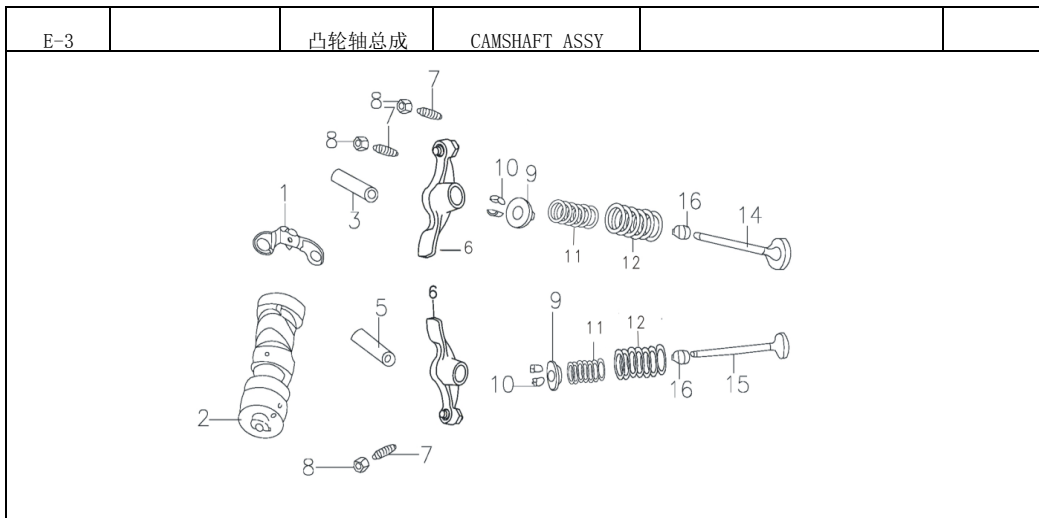

NO.	ICEBEAR PART NO.	FACTORY PART NO.	CHINESE NAME	English Name	QTY
1	PAD125-3-E-E-001	E03F011	正时从动链轮	TIMING DRIVEN SPROCKET	1
2	PAD125-3-E-E-002	E03F012	正时链条	TIMING CHAIN	1
3	PAD125-3-E-E-003	D00F043	链条张紧臂组件	CHAIN TENSION ARM SUBASSEMBLY	1
4	PAD125-3-E-E-004	D00C020	链条张紧滚轮组合	CHAIN TENSION CONTACT ROLLER ASSEMBLY	1
5	PAD125-3-E-E-005	D00F044	链条张紧臂芯轴	CHAIN TENSION ARM MANDREL	1
6	PAD125-3-E-E-006	D00H006	链条张紧杆弹簧	CHAIN TENSION STUD SPRING	1
7	PAD125-3-E-E-007	D00F042	链条张紧杆组件	CHAIN TENSION STUD SUBASSEMBLY	1
8	PAD125-3-E-E-008	D00C022	链条张紧杆头	CHAIN TENSION STUD HEAD	1
9	PAD125-3-E-E-009	E03C023	无芯导向轮	GUIDE WHEEL WITHOUT CORE	1
10	PAD125-3-E-E-010	D00F048	导向滚轮销	GUIDE ROLLER PIN	1
11	PAD125-3-E-E-011	E04C021	链条张紧滚轮 2	CHAIN TENSION CONTACT ROLLER II	1
12	PAD125-3-E-E-012	E04F041	链条张紧滚轮 2 销轴	CHAIN TENSION CONTACT ROLLER II PIN	1
13	PAD125-3-E-E-013	D00E025	密封螺栓	SEAL BOLT	1
14	PAD125-3-E-E-014	578305012	六角螺栓M5×12	BOLT M5×12	3
15	PAD125-3-E-E-015	D00L021	铝垫圈14	ALUMINIUM WASHER 14	1
16	PAD125-3-E-E-016	208-4-16	垫圈	WASHER	1
17	PAD125-3-E-E-017	D00L019	铝垫圈8	ALUMINIUM WASHER 8	1
18	PAD125-3-E-E-018	D00L020	螺栓	BOLT	1

E-5		左、右箱体	CRANKCASE		
NO.	ICEBEAR PART NO.	FACTORY PART NO.	CHINESE NAME	English Name	QTY
1	PAD125-3-E-F-001	203A020PW	右曲轴箱体	RIGHT CRANKCASE BODY	1
2	PAD125-3-E-F-002	E04B005	曲轴箱密封垫	CRANKCASE SEALED PACKING	1
3	PAD125-3-E-F-003	203A010PW	左曲轴箱体	LEFT CRANKCASE BODY	1
4	PAD125-3-E-F-004	F00C024	通气管	BREATHING PIPE	1
7	PAD125-3-E-F-005	206M001	汽缸双头螺栓 A	CYLINDER TRAPPED STUD(A)	2
8	PAD125-3-E-F-006	206M002	汽缸双头螺栓 B	CYLINDER TRAPPED STUD (B)	2
11	PAD125-3-E-F-007	D00E026BX	放油螺栓	DISCHARGING OIL PLUG SCREW	1
15	PAD125-3-E-F-008	D001C008	油封	WASHER	1
16	PAD125-3-E-F-009	D00C026	油封	WASHER	1

E-6		曲轴总成	CRANKSHAFT		
NO.	ICEBEAR PART NO.	FACTORY PART NO.	CHINESE NAME	English Name	QTY
1	PAD125-3-E-G-001	2154J000	曲柄连杆组件	CRANK CONNECTING ROD	1
2	PAD125-3-E-G-002	E001J013	活塞环组合	PISTON RING SET	1
3	PAD125-3-E-G-003	215J014	活塞	PISTON	1
4	PAD125-3-E-G-004	204J012	活塞销	PISTON PIN	1
5	PAD125-3-E-G-005	204J011	活塞销挡圈	PISTON PIN SHIELD RING	2
14	PAD125-3-E-G-006	A00K015	主动齿轮	PRIMARY DRIVER GEAR	1

E-7		右边盖	CRANKCASE COVER		
NO.	ICEBEAR PART NO.	FACTORY PART NO.	CHINESE NAME	English Name	QTY
1	PAD125-3-E-H-001	D01A034PW	右曲轴箱盖	RIGHT CRANKCASE COVER	1
	PAD125-3-E-H-002	D01A034PW01	右大盖装饰盖/IRBIS	RIGHT COVER/IRBIS	1
2	PAD125-3-E-H-003	E04B002	密封垫	RIGHT CRANKCASE SEALED	1
3	PAD125-3-E-H-004	97108012	定位销	PITCHED PIN	2
7	PAD125-3-E-H-005	D00C038	机油标尺组合	OIL SCALE ASSEMBLY	1
8	PAD125-3-E-H-006	D00C060	O型密封圈	O-SHAPED SEALED RING	1
9	PAD125-3-E-H-007	D00C016	油封	OIL SEAL	1
11	PAD125-3-E-H-008	E13G010BCR	离合器操纵杆	CLUTCH CONTROL LEVER	1
12	PAD125-3-E-H-009	E13H007	操纵杆复位弹簧	CONTROL LEVER RETURN SPRING	1
13	PAD125-3-E-H-010	F04C030	油封	OIL SEAL	1
14	PAD125-3-E-H-011	208-7-14	增油导管	OIL PIPE	1

E-8		左曲轴箱盖 磁电机	Left Crankcase Cover & Magneto		
NO.	ICEBEAR PART NO.	FACTORY PART NO.	CHINESE NAME	English Name	QTY
1	PAD125-3-E-I-001	A019A070PW	左边盖	LEFT CRANKCASE COVER	1
2	PAD125-3-E-I-002	A017D000	磁电机总成普70	MAGNETON	1
3	PAD125-3-E-I-003	A018D060	磁电机转子普70	FLYWHEEL	1
4	PAD125-3-E-I-004	A0229D070	磁电机定子普70	STATOR MODULE	1
5	PAD125-3-E-I-005	617710000BCR-1	六角螺母	HEX NUT	1
7	PAD125-3-E-I-006	D001C062	O型密封圈	O-SHAPED SEAL	1
9	PAD125-3-E-I-007	GB818	螺钉	BOLT	2
6	PAD125-3-E-I-008	D00C028	油封	OILE SEAL	1
8	PAD125-3-E-I-009	F002C048	O型密封圈	O-SHAPED SEAL	1

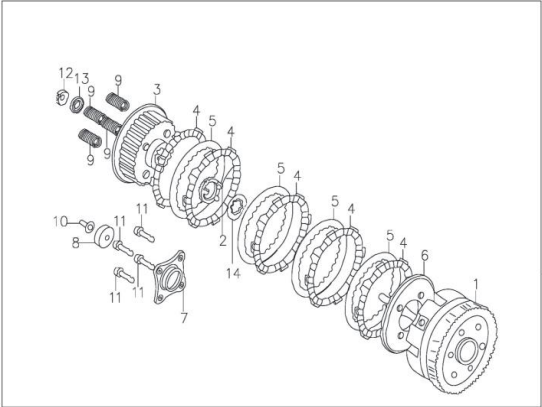
E-9	离合器组件		CLUTCH COMPONENT PART		
					
NO.	ICEBEAR PART NO.	FACTORY PART NO.	CHINESE NAME	English Name	QTY
14	PAD125-3-E-J-001	208-9-14	花键垫圈	SPLINE SHAFT WASHER	1
15	PAD125-3-E-J-002	200G060	离合器总成/手离合	CLUTCH ASSEMBLY	1

E-10		变速鼓组件	SHIFTING MOTIVATOR		
NO.	ICEBEAR PART NO.	FACTORY PART NO.	CHINESE NAME	English Name	QTY
8	PAD125-3-E-K-001	D05K070	变速鼓定位板组件	SPEED VARIATOR STRONGBAC	1
20	PAD125-3-E-K-002	A004K060	变速鼓组合	SHIFTING YOKE VARIATOR	1
21	PAD125-3-E-K-003	C03K000	换挡臂组件	SHIFTING SUBASSEMBLY	1

E-11		起动机轴组合	START ASSY	
------	--	--------	------------	--

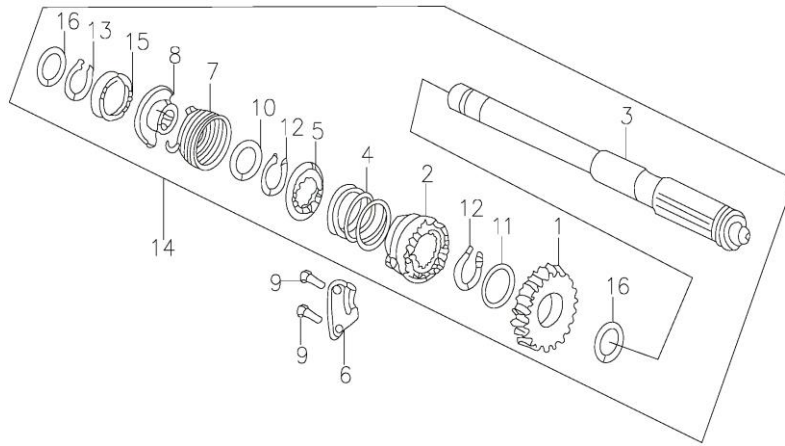

NO.	ICEBEAR PART NO.	FACTORY PART NO.	CHINESE NAME	English Name	QTY
\$14.00	PAD125-3-E-L-003	208-11-3	起动机轴总成	Starting shaft assembly	1
E-12		主、副轴组件	SLOWING DOWN SUBASSEMBLY		

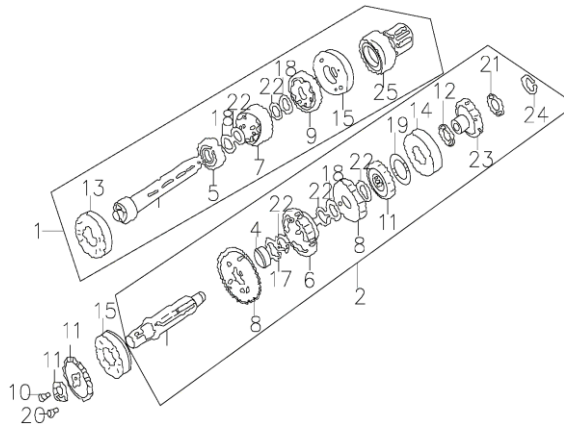

NO.	ICEBEAR PART NO.	FACTORY PART NO.	CHINESE NAME	English Name	QTY
1	PAD125-3-E-M-001	E05K030	传动主轴 (不含轴承)	TRANSMISSION MAIN SHAFT	1
2	PAD125-3-E-M-002	A001K040	传动副轴 (不含轴承)	TRANSMISSION COUNTER SHAFT	1
12	PAD125-3-E-M-003	208-12-12	主动链轮卡圈	DRIVE SPROCKET CLOSING RING	1
E-13		油泵总成	PUMP ASSY		

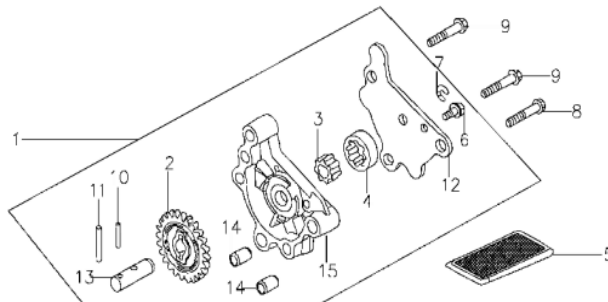

NO.	ICEBEAR PART NO.	FACTORY PART NO.	CHINESE NAME	English Name	QTY
1		2001E000/	机油泵部件	OIL PUMP COMPONENTS	1