

Part No.	Description	Qty per Vehicel
PMZ200-V-A-001	REAR MIRROR,L	1
PMZ200-V-A-002	REAR MIRROR,R	1
PMZ200-V-A-003	Handlbar	1
PMZ200-V-A-004	Upper,fixation base	1
PMZ200-V-A-005	Lower,fixation base	1
PMZ200-V-A-006	Deco cover,fixation base	1
PMZ200-V-A-007	Upper Deco cover,fixation base	1
PMZ200-V-A-008	Lower Deco cover,fixation base	1
PMZ200-V-A-009	Main,throttle wire	1
PMZ200-V-A-010	Wire clip (φ8.5)	2
PMZ200-V-A-011	SWITCH,HANDLEBAR L	1
PMZ200-V-A-012	SWITCH,HANDLEBAR R	1
PMZ200-V-A-013	L.GRIP,HANDLE	1
PMZ200-V-A-014	R.GRIP,HANDLE	1
PMZ200-V-A-015	Expansion button	2
PMZ200-V-A-016	Balance block	2
PMZ200-V-A-017	BRIDGE FORK TOP	1
PMZ200-V-A-018	Cover,bolt of handlbar	4
PMZ200-V-A-019	Bolt M8*30	4

PMZ200-V-A-020	Bolt M6*75	2
PMZ200-V-A-021	Nut M6	2
PMZ200-V-A-022	Lock nut M10	3
PMZ200-V-A-023	Lock spacer 1,Φ10 (+0.1) *Φ21	1
PMZ200-V-A-024	Lock spacer 2,Φ10	1
PMZ200-V-A-025	Bolt M6X20	1
PMZ200-V-A-026	Step screw M6*12	2
PMZ200-V-A-027	Washer,Φ10*Φ21*2	2

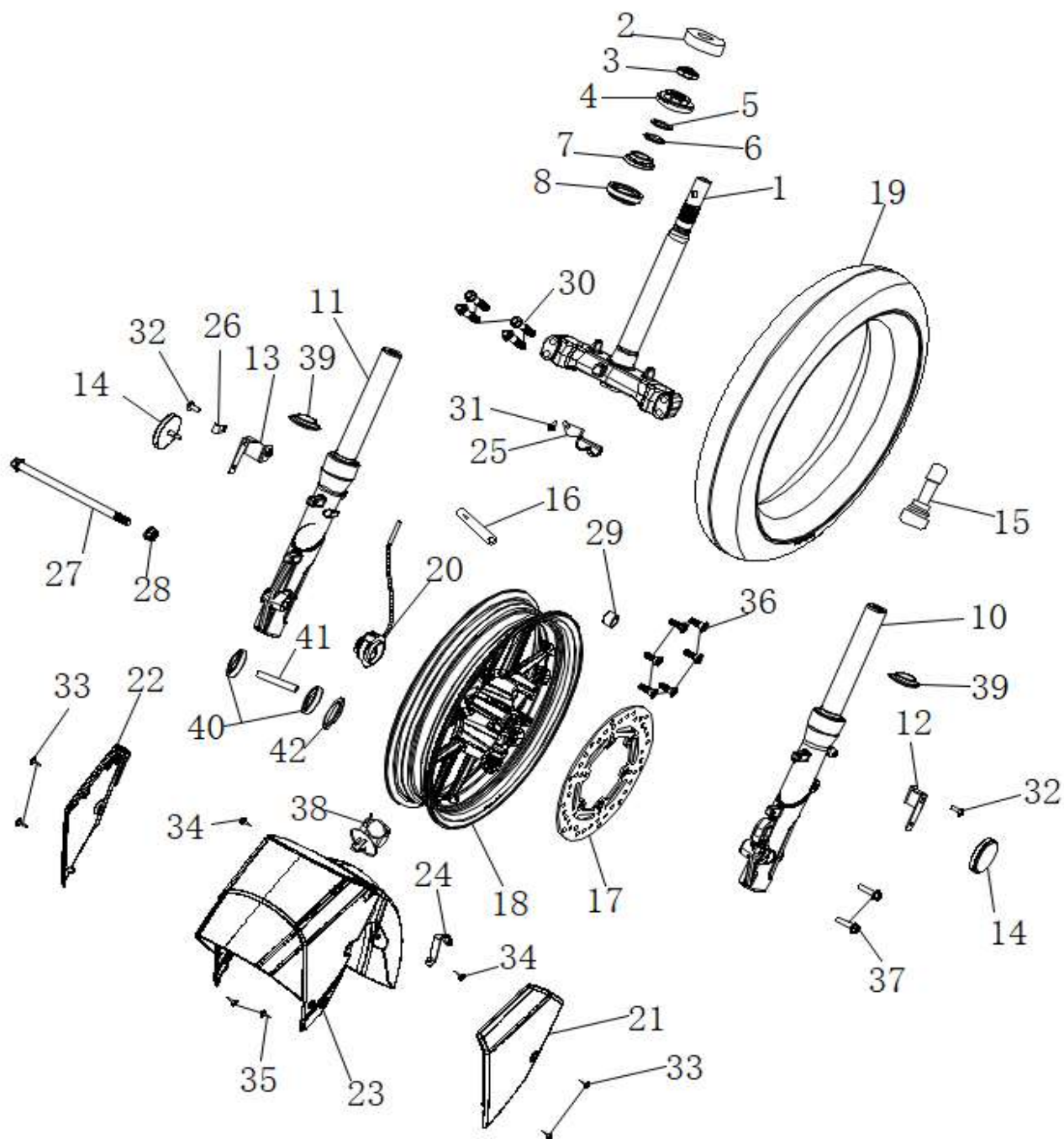

Part No.	Description	Qty per Vehicle
PMZ200-V-B-001	Steering Steam	1
PMZ200-V-B-002	DUST COVER 1	1

PMZ200-V-B-003	Upper locking Nut	1
PMZ200-V-B-004	Lower Locking Nut	1
PMZ200-V-B-005	DUST COVER 2	1
PMZ200-V-B-006	Lock washer,upper bearing	1
PMZ200-V-B-007	STEERING BEARING	1
PMZ200-V-B-010	L.FR.FORK ASSY.	1
PMZ200-V-B-011	R.FR.FORK ASSY.	1
PMZ200-V-B-012	L Bracket,Fr fender	1
PMZ200-V-B-013	R Bracket,Fr fender	1
PMZ200-V-B-014	Side Reflector	2
PMZ200-V-B-015	VALVE RIM	1
PMZ200-V-B-016	RUBBER TIE 2	1
PMZ200-V-B-017	Front disc	1
PMZ200-V-B-018	Front Rim	1
PMZ200-V-B-019	Front Tire	1
PMZ200-V-B-020	Speed Counter	1
PMZ200-V-B-021	L cover,FR fender	1
PMZ200-V-B-022	R cover,FR fender	1
PMZ200-V-B-023	FR fender	1
PMZ200-V-B-024	BRAKE TUBE CLIP 1	1
PMZ200-V-B-025	BRAKE TUBE CLIP 1	1
PMZ200-V-B-026	Clip,wire,gear sensor ABS	1
PMZ200-V-B-027	FR AXLE	1
PMZ200-V-B-028	Self locking nut M12*1.25	1
PMZ200-V-B-029	Spacer R,Fr axle	1
PMZ200-V-B-030	Bolt M10*40*1.25	4
PMZ200-V-B-031	Bolt M6X12	1
PMZ200-V-B-032	Hexagon socket screw	2
PMZ200-V-B-033	Hexagon socket screw M6X15	4
PMZ200-V-B-034	Hexagon socket screw M6X16	2
PMZ200-V-B-035	SCREW ST4.2*12	2
PMZ200-V-B-036	Step bolt,Disc,M8*25	6
PMZ200-V-B-037	Bolt M8X30	2
PMZ200-V-B-038	Wire clip (φ8.5)	1
PMZ200-V-B-039	Oil seal, Fr absorber	2
PMZ200-V-B-040	Bering,Fr rim	2
PMZ200-V-B-041	Inner bushing,Fr rim	1

PMZ200-V-B-042	Oil seal, Fr rim	1
----------------	------------------	---

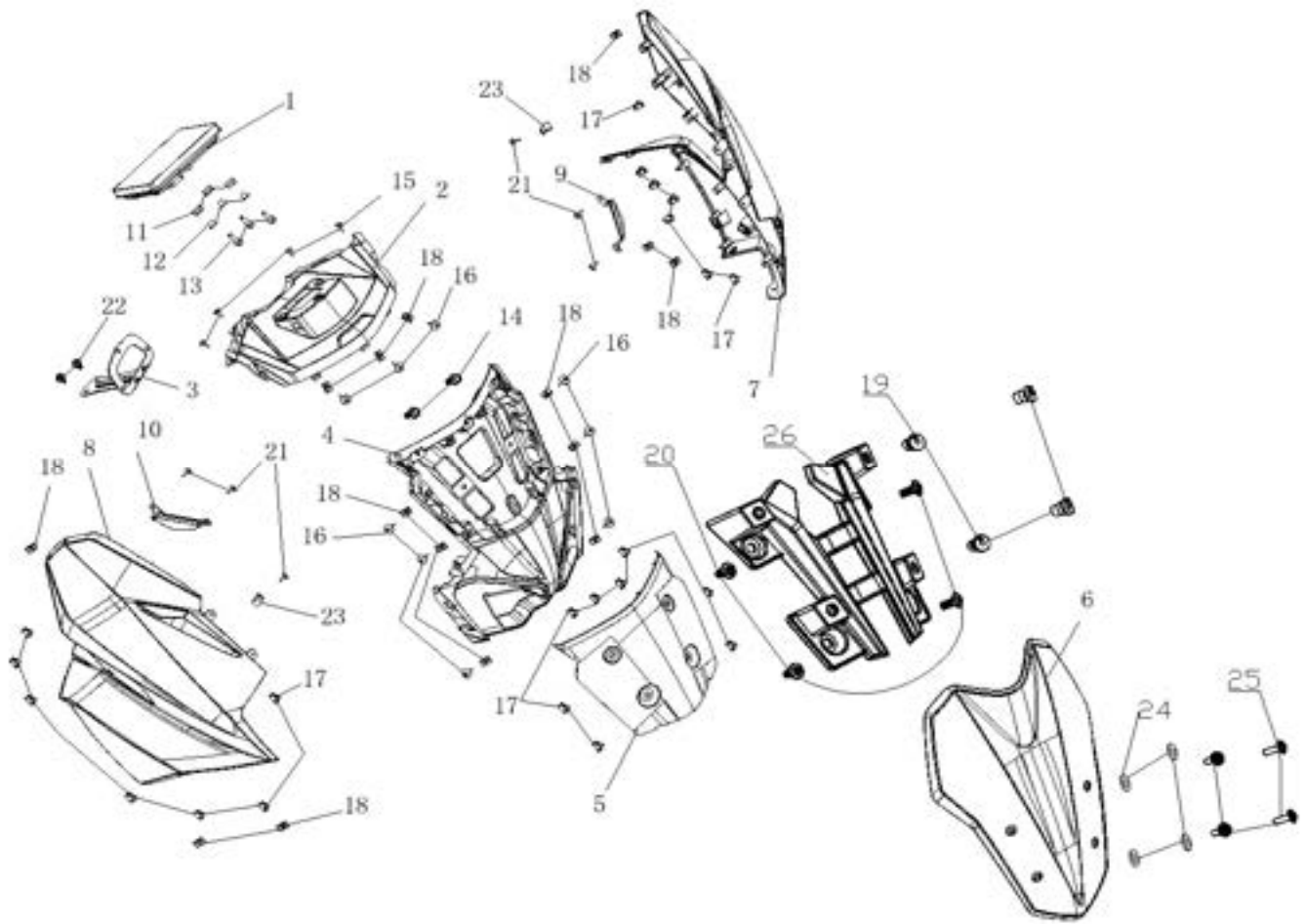

Part No.	Description	Qty per Vehicle
PMZ200-V-C-001	Speedmeter,VA	1
PMZ200-V-C-002	Meter cover	1
PMZ200-V-C-003	Bracket,Dash	1
PMZ200-V-C-004	COVER FR TOP	1
PMZ200-V-C-005	Dec cover,COVER FR TOP	1
PMZ200-V-C-006	Windshield	1
PMZ200-V-C-007	FRONT COVER L	1
PMZ200-V-C-008	FRONT COVER R	1
PMZ200-V-C-009	Ventilation grid,L	1
PMZ200-V-C-010	Ventilation grid,R	1
PMZ200-V-C-011	Rubber Ring	3
PMZ200-V-C-012	Bush	3
PMZ200-V-C-013	Bolt M5X20	3
PMZ200-V-C-014	Bolt M6X12	2
PMZ200-V-C-015	SCREW ST4.2*12	4
PMZ200-V-C-016	Pan screw,ST4.8*16	9
PMZ200-V-C-017	Buckle,plastic	22

PMZ200-V-C-018	NUT SPRING 4MM	15
PMZ200-V-C-019	RUBBER NUT,M5	4
PMZ200-V-C-020	Hexagon socket Step screw M6X15	4
PMZ200-V-C-021	Pan screw,ST4.2*10	4
PMZ200-V-C-022	Bolt M6X12	2
PMZ200-V-C-023	Black wire clip	2
PMZ200-V-C-024	CUSION WASHER,WINDSCREEN	4
PMZ200-V-C-025	Hexagon Screw	4
PMZ200-V-C-026	Fixation plate,windscreen	1

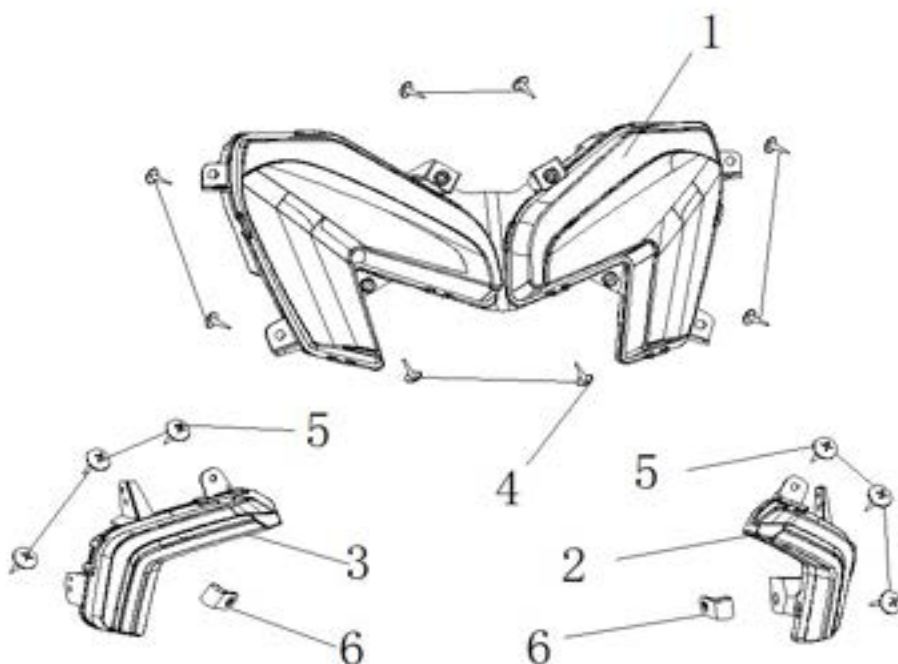

Part No.	Description	Qty per Vehicel
PMZ200-V-D-001	HEADLIGHT	1
PMZ200-V-D-002	L FR turn signal	1
PMZ200-V-D-003	R FR turn signal	1
PMZ200-V-D-004	SCREW ST4.2*12	8
PMZ200-V-D-005	Pan screw,ST4.8*16	6
PMZ200-V-D-006	Black wire clip	2

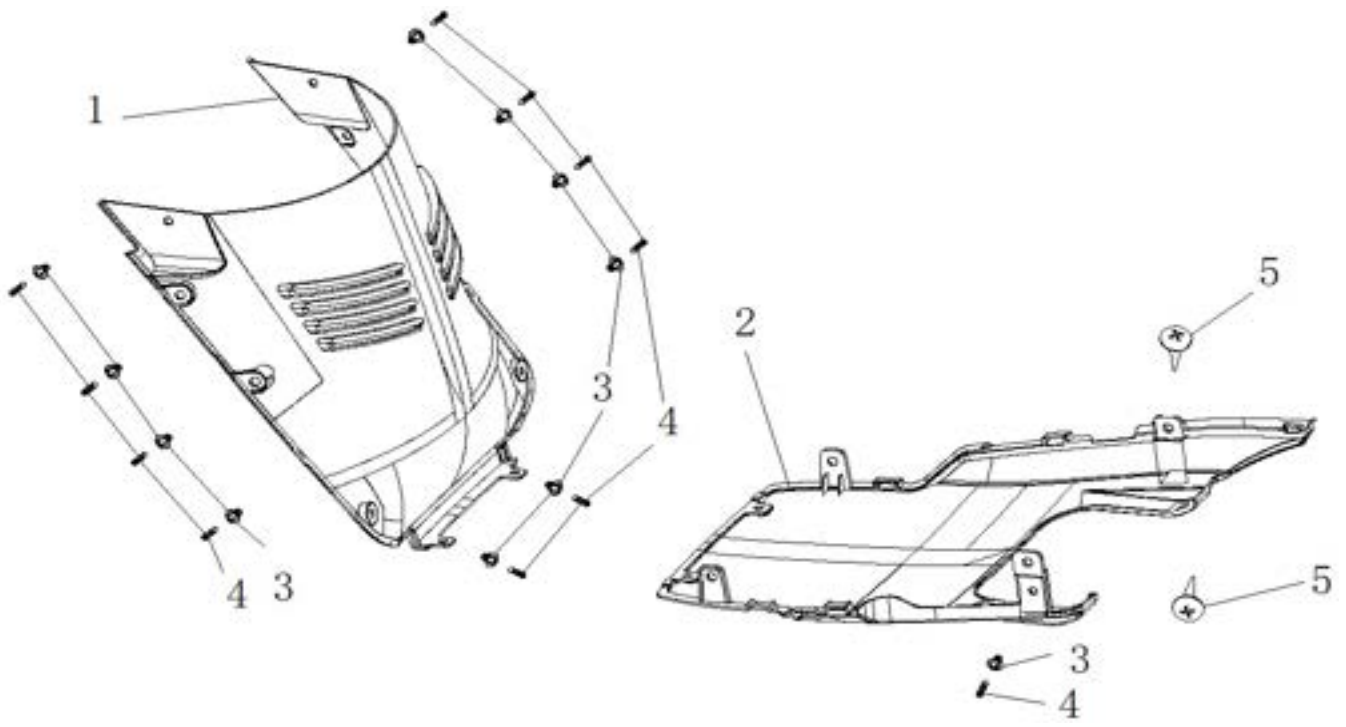

Part No.	Description	Qty per Vehicel
PMZ200-V-E-001	Front grille	1
PMZ200-V-E-002	Frame base cover	1
PMZ200-V-E-003	EXPANSION NAIL BODY	11
PMZ200-V-E-004	EXPANSION NAIL	11
PMZ200-V-E-005	Pan screw,M6*12	2

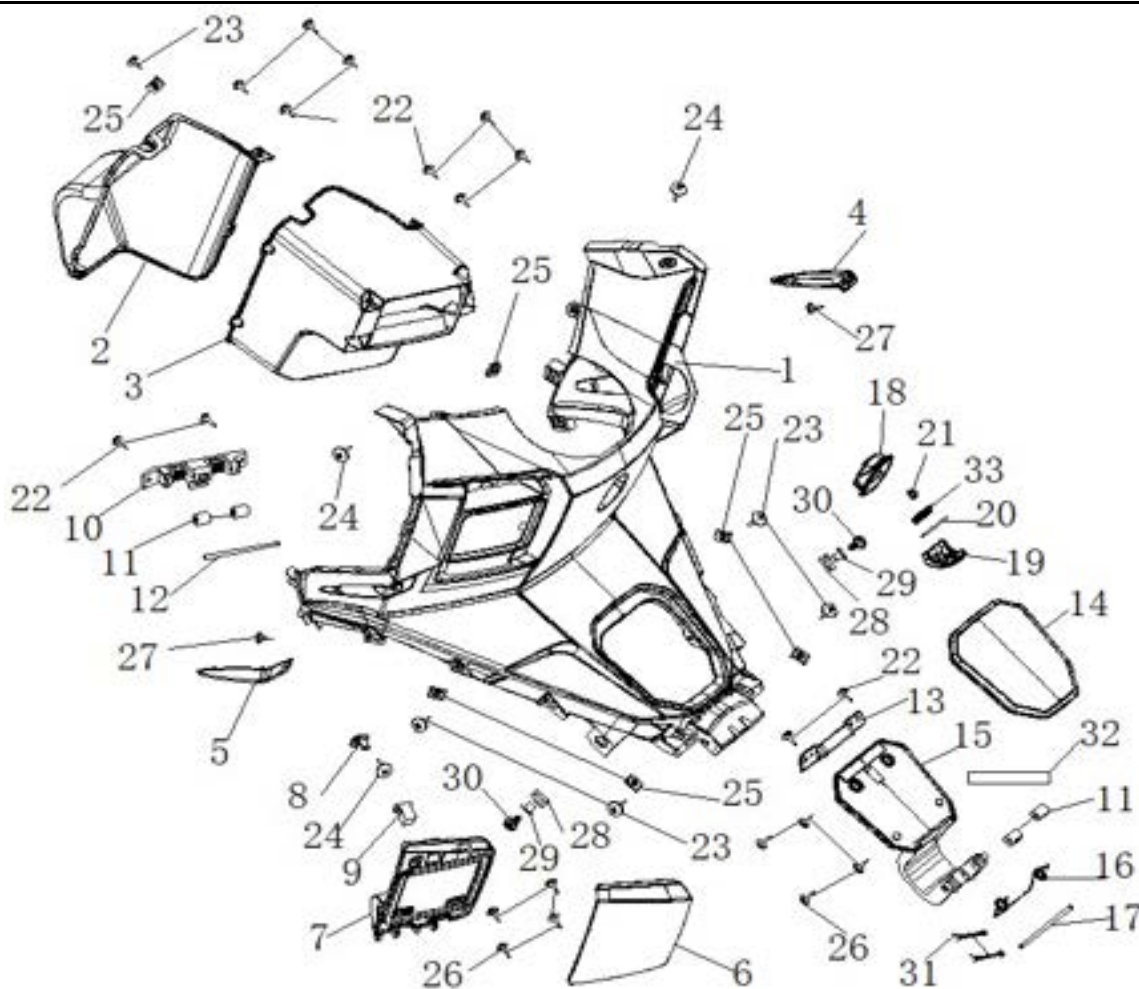

Part No.	Description	Qty per Vehicel
PMZ200-V-F-001	TOOLBOX	1
PMZ200-V-F-002	L TOOLBOX BUCKET COVER	1
PMZ200-V-F-003	L TOOLBOX BUCKET	1
PMZ200-V-F-004	L TOOLBOX,cover	1
PMZ200-V-F-005	R TOOLBOX,cover	1
PMZ200-V-F-006	L TOOLBOX OUTER COVER	1
PMZ200-V-F-007	L TOOLBOX INNER COVER	1
PMZ200-V-F-008	Lock hook,L tool box	1
PMZ200-V-F-009	Lock Base,Tool box	1
PMZ200-V-F-010	L Toolbox cover fixing plate	1
PMZ200-V-F-011	Toolbox Damper	4
PMZ200-V-F-012	Pin,tool box	1
PMZ200-V-F-013	Fuel Tank Lock Stay	1
PMZ200-V-F-014	FEUL TANK COVER	1
PMZ200-V-F-015	Fuel Tank Cover Swim Arm	1
PMZ200-V-F-016	Fuel tank cover spring	1
PMZ200-V-F-017	Fuel cover pin	1
PMZ200-V-F-018	Bootom cover ,hook tool box	1

PMZ200-V-F-019	Outer cover ,hook tool box	1
PMZ200-V-F-020	Pin,hook tool box	1
PMZ200-V-F-021	Bolt M6X12	1
PMZ200-V-F-022	SCREW ST4.2*12	12
PMZ200-V-F-023	Pan screw,ST4.8*16	5
PMZ200-V-F-024	Pan screw,ST4.8*12	3
PMZ200-V-F-025	NUT SPRING 4MM	6
PMZ200-V-F-026	Pan screw,ST4.2*12,Dechrom	8
PMZ200-V-F-027	Screw ST3.5*8	2
PMZ200-V-F-028	Rubber Ring	2
PMZ200-V-F-029	Bush	2
PMZ200-V-F-030	Pan screw,M6*16	2
PMZ200-V-F-031	Wave pin	2
PMZ200-V-F-032	Sponge,Cover,oil tank	1
PMZ200-V-F-033	Spring,hook	1

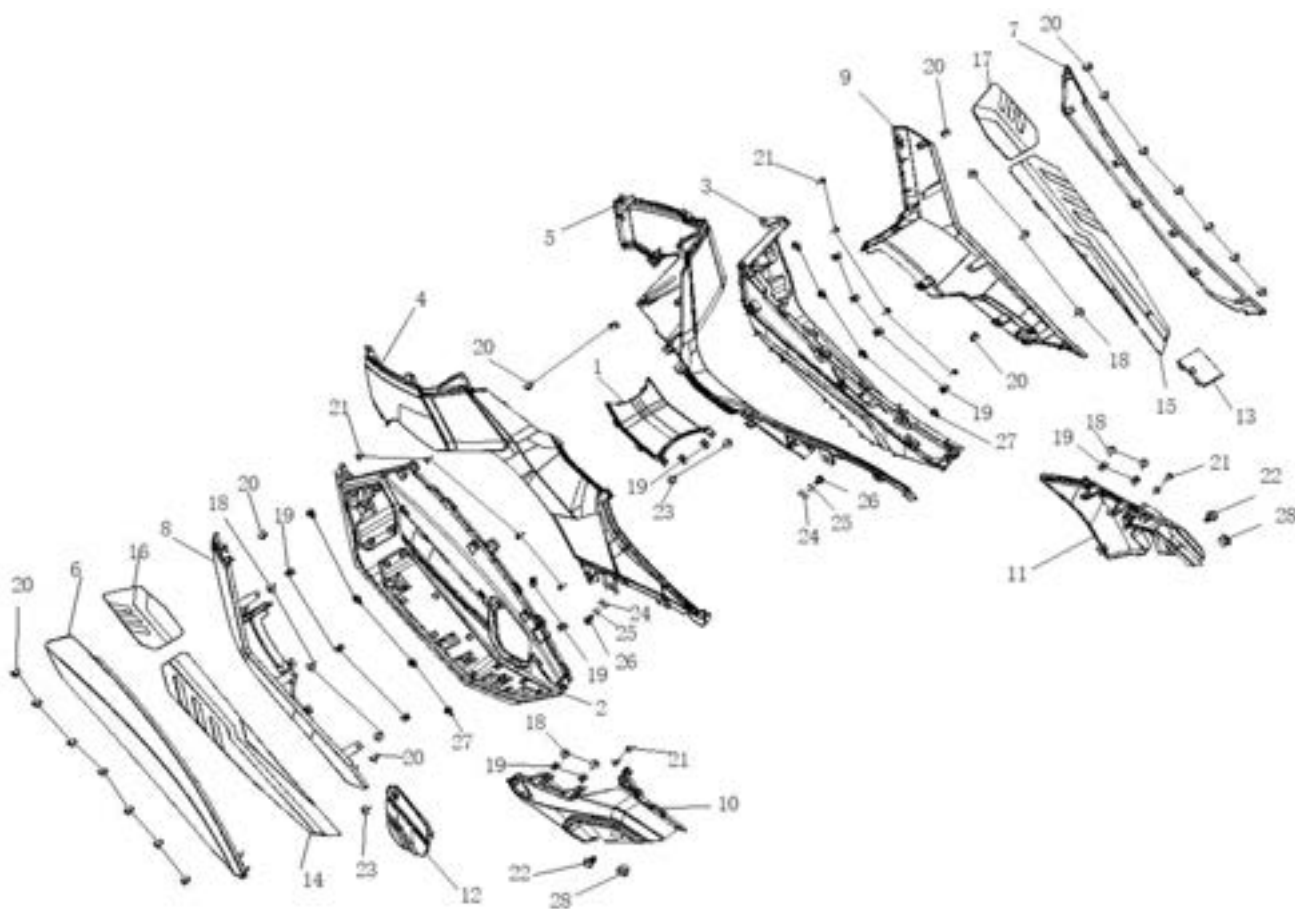

Part No.	Description	Qty per Vehicel
PMZ200-V-G-001	Foot pedal cover,upper	1
PMZ200-V-G-002	L foot pedal	1
PMZ200-V-G-003	R foot pedal	1
PMZ200-V-G-004	Upper cover of L foot pedal	1

PMZ200-V-G-005	Upper cover of R foot pedal	1
PMZ200-V-G-006	L Decorative cover	1
PMZ200-V-G-007	R Decorative cover	1
PMZ200-V-G-008	L Side cover	1
PMZ200-V-G-009	R Side cover	1
PMZ200-V-G-010	L bar RR	1
PMZ200-V-G-011	R bar RR	1
PMZ200-V-G-012	Cover,L. Pedal	1
PMZ200-V-G-013	Cover,R. Pedal	1
PMZ200-V-G-014	FL. Pedal Cover,RUBBER	1
PMZ200-V-G-015	FR. Pedal Cover,RUBBER	1
PMZ200-V-G-016	L. Pedal Cover,RUBBER	1
PMZ200-V-G-017	R. Pedal Cover,RUBBER	1
PMZ200-V-G-018	Pan screw,ST4.8*16	10
PMZ200-V-G-019	NUT SPRING 4MM	15
PMZ200-V-G-020	Buckle,plastic	20
PMZ200-V-G-021	SCREW ST4.2*12	12
PMZ200-V-G-022	Hexagon socket screw M6X15	2
PMZ200-V-G-023	Pan screw,ST4.8*12	3
PMZ200-V-G-024	Rubber Ring	2
PMZ200-V-G-025	Bush	2
PMZ200-V-G-026	Bolt M6X16	2
PMZ200-V-G-027	Bolt M6X14	8
PMZ200-V-G-028	Limit rubber,foot rest	2

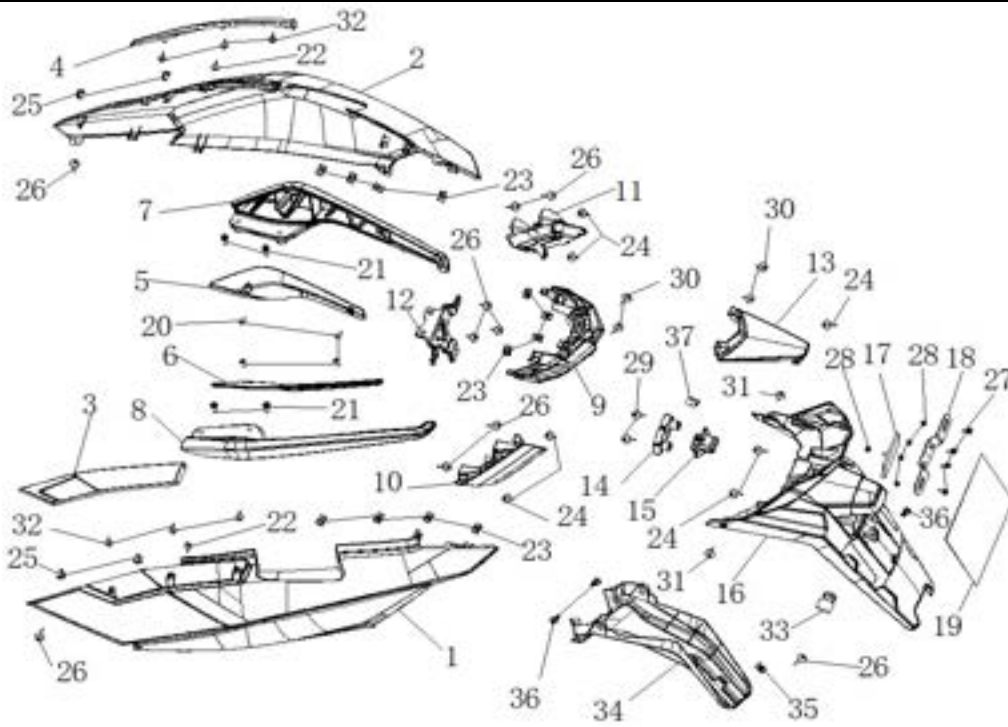

Part No.	Description	Qty per Vehicel
PMZ200-V-H-001	Cover set L body	1
PMZ200-V-H-002	Cover set R body	1
PMZ200-V-H-003	Dec cover,Cover set L body	1
PMZ200-V-H-004	Dec cover,Cover set R body	1
PMZ200-V-H-005	Deco cover,L rear carrier	1
PMZ200-V-H-006	Deco cover,R rear carrier	1
PMZ200-V-H-007	Left rear carrier	1
PMZ200-V-H-008	Right rear carrier	1
PMZ200-V-H-009	Tail light	1
PMZ200-V-H-010	WINKER ASSY.. L . RR	1
PMZ200-V-H-011	WINKER ASSY.. R . RR	1
PMZ200-V-H-012	Connect plate,tail light	1
PMZ200-V-H-013	Rear lamp upper cover	1
PMZ200-V-H-014	Fixation plate,license light	1
PMZ200-V-H-015	License plate light	1
PMZ200-V-H-016	REAR FENDER	1
PMZ200-V-H-017	RR Reflector	1
PMZ200-V-H-018	Plate Holder	1
PMZ200-V-H-019	Plate	4
PMZ200-V-H-020	Pan screw,M5*10	4
PMZ200-V-H-021	Bolt M8X40	4
PMZ200-V-H-022	Bolt M6X14	1
PMZ200-V-H-023	NUT SPRING 4MM	12

PMZ200-V-H-024	SCREW ST4.2*12	9
PMZ200-V-H-025	Buckle,plastic	4
PMZ200-V-H-026	Pan screw,ST4.8*16	8
PMZ200-V-H-027	Bolt M6X16	4
PMZ200-V-H-028	Nut M6	5
PMZ200-V-H-029	Screw ST4.2*16	2
PMZ200-V-H-030	Pan screw,ST4.8*12	6
PMZ200-V-H-031	Pan screw,ST4.8*12	2
PMZ200-V-H-032	SCREW ST4.2*10	6
PMZ200-V-H-033	Plate, rubber mat	1
PMZ200-V-H-034	Lower part,rear fender	1
PMZ200-V-H-035	NUT SPRING 4MM	1
PMZ200-V-H-036	Bolt M6X12	2
PMZ200-V-H-037	Black wire clip	1

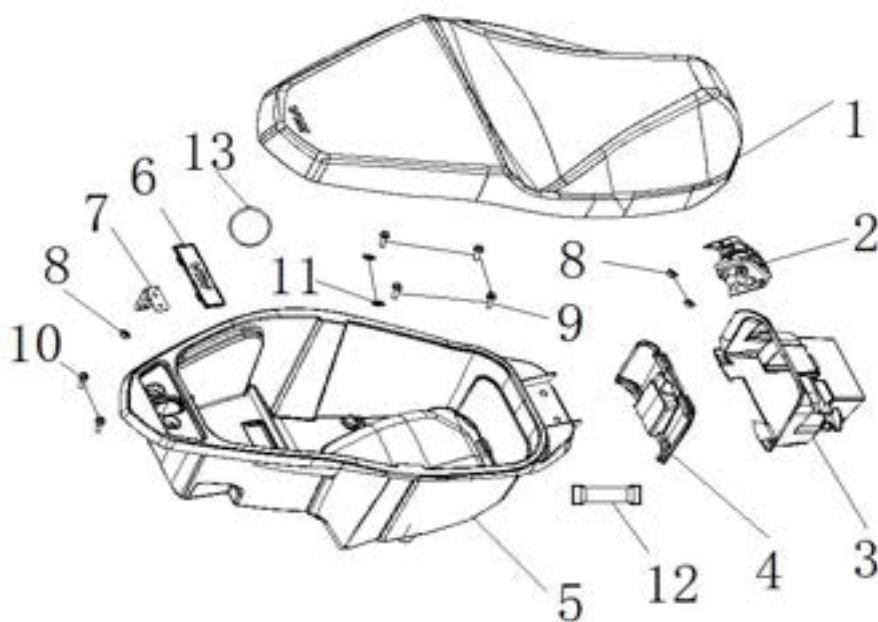

Part No.	Description	Qty per Vehicel
PMZ200-V-I-001	SEAT	1
PMZ200-V-I-002	Seat Rocker	1
PMZ200-V-I-003	Battery cover	1
PMZ200-V-I-004	Battery box cover	1
PMZ200-V-I-005	Luggage box	1
PMZ200-V-I-006	Vin cover	1
PMZ200-V-I-007	SEAT LOCK	1
PMZ200-V-I-008	Nut M6	3
PMZ200-V-I-009	Bolt M6X16	4

PMZ200-V-I-010	Bolt M6X14	2
PMZ200-V-I-011	Washer,Φ6*Φ18*1.6	2
PMZ200-V-I-012	TITLE,BATTERY	1
PMZ200-V-I-013	O RING	1

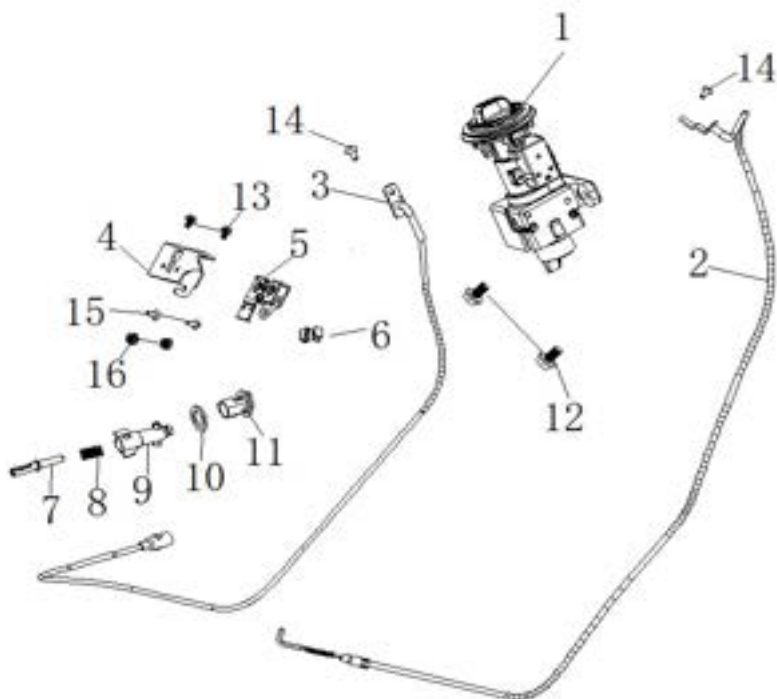

Part No.	Description	Qty per Vehicel
PMZ200-V-J-001	LOCK,ordinary	1
PMZ200-V-J-002	Seat cushion cable	1
PMZ200-V-J-003	Fuel tank lock wire	1
PMZ200-V-J-004	Bracket of Seat locker	1
PMZ200-V-J-005	Battery protector locker	1
PMZ200-V-J-006	Battery protector cable sheath	1
PMZ200-V-J-007	WHOLE SET,LOCK OF OIL TANK	1
PMZ200-V-J-008	Spring,LOCK,TANK	1
PMZ200-V-J-009	Main body,LOCK,TANK	1
PMZ200-V-J-010	Rubber washer,LOCK,TANK	1
PMZ200-V-J-011	Cover,LOCK,TANK	1
PMZ200-V-J-012	Bolt M6X16	2
PMZ200-V-J-013	Bolt M6X12	2
PMZ200-V-J-014	Bolt M5X8	2
PMZ200-V-J-015	Pan screw,M4*20	2
PMZ200-V-J-016	LOCKING NUT M4	2

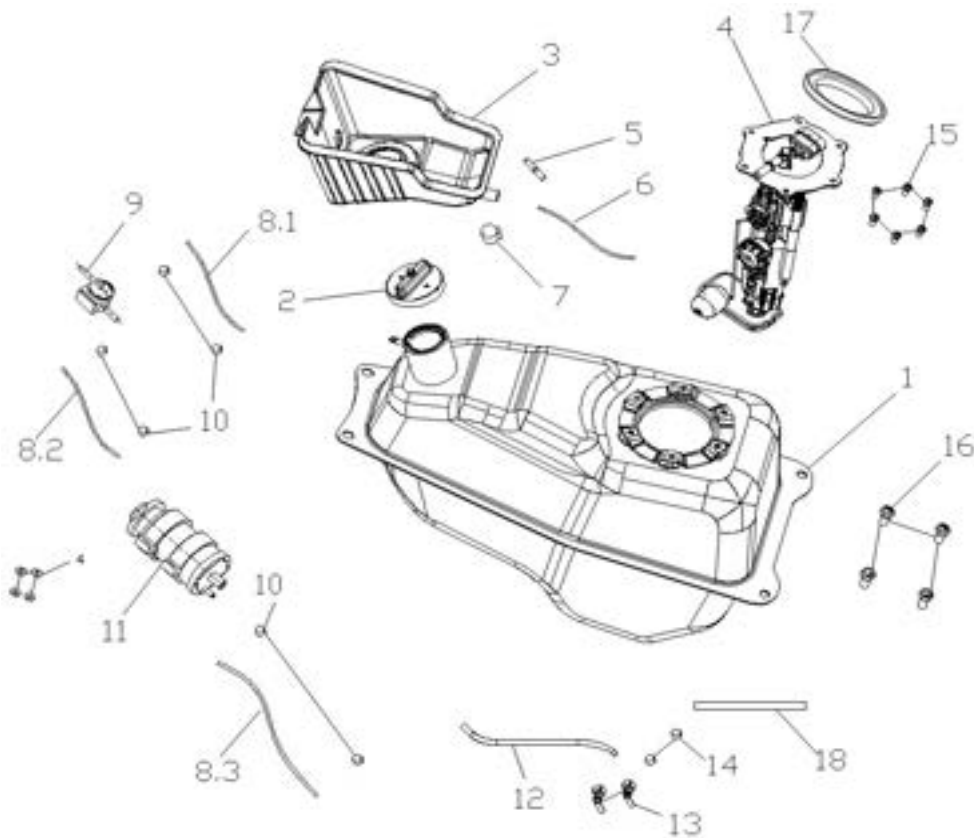

Part No.	Description	Qty per Vehicel
PMZ200-V-K-001	Fuel tank	1
PMZ200-V-K-002	Cap, Tank	1
PMZ200-V-K-003	Filler sleeve	1
PMZ200-V-K-004	FUEL PUMP	1
PMZ200-V-K-005	Connector	1
PMZ200-V-K-006	Carbon canister pipe	1
PMZ200-V-K-007	Clip, Carbon canister pipe	1
PMZ200-V-K-008-1	Negative pressure tube 230mm	1
PMZ200-V-K-008-2	Negative pressure tube 570mm	1
PMZ200-V-K-008-3	Negative pressure tube 510mm	1
PMZ200-V-K-009	Dump valve	1
PMZ200-V-K-010	Clip, fuel tube (φ8)	6
PMZ200-V-K-011	Carbon canister	1
PMZ200-V-K-012	High pressure tube	1
PMZ200-V-K-013	Fast-connector, Vertical	2
PMZ200-V-K-014	Clamp, High pressure tube	2
PMZ200-V-K-015	Bolt M5*12	6
PMZ200-V-K-016	Bolt M8*12	4
PMZ200-V-K-017	Fuel Pump Seal	1
PMZ200-V-K-018	Pipe fixation	1

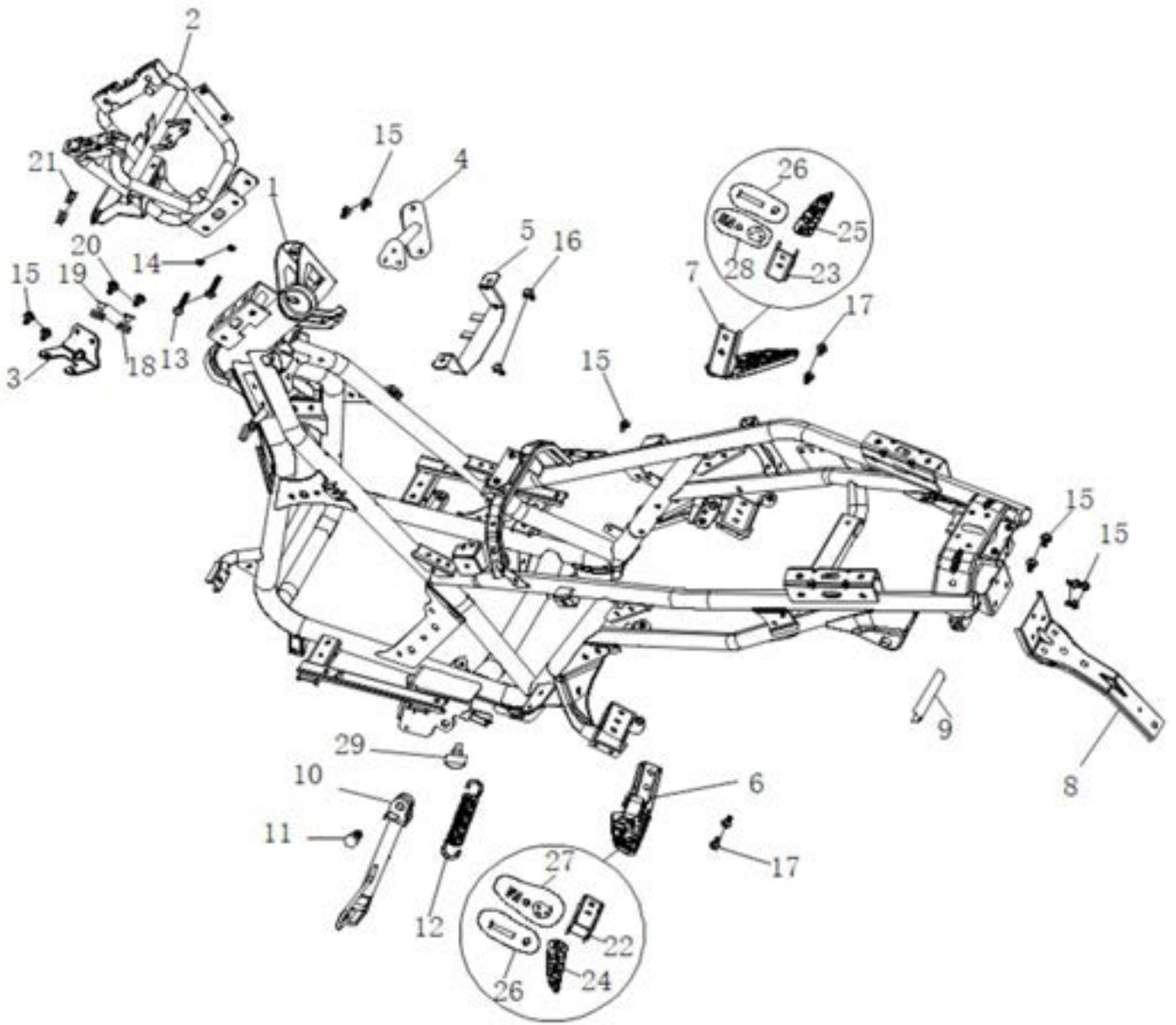

Part No.	Description	Qty per Vehicle
PMZ200-V-L-001	Frame assy	1
PMZ200-V-L-002	Bracket,head light	1
PMZ200-V-L-003	Holder,proportional VALVE	1
PMZ200-V-L-004	Holder,RELAY	1
PMZ200-V-L-005	Battery Bracket	1
PMZ200-V-L-006	BAR L STEP ASSY	1
PMZ200-V-L-007	BAR R STEP ASSY	1
PMZ200-V-L-008	REAR FENDER STAY	1
PMZ200-V-L-009	VIN PLATE	1
PMZ200-V-L-010	Side Stand	1
PMZ200-V-L-011	Side Stand Bolt	1
PMZ200-V-L-012	Side Stand double spring	1
PMZ200-V-L-013	Bolt M8*55	2
PMZ200-V-L-014	Nut M8	2

PMZ200-V-L-015	Bolt M6X12	10
PMZ200-V-L-016	Bolt M6X14	2
PMZ200-V-L-017	Blot M8*16	4
PMZ200-V-L-018	Rubber Ring	2
PMZ200-V-L-019	Bush	2
PMZ200-V-L-020	Bolt M6*40	2
PMZ200-V-L-021	Rubber ring,panel	2
PMZ200-V-L-022	Holder,LR foot rest	1
PMZ200-V-L-023	Holder,RR foot rest	1
PMZ200-V-L-024	LR foot rest	1
PMZ200-V-L-025	RR foot rest	1
PMZ200-V-L-026	PIN SET	2
PMZ200-V-L-027	LIMIT PLATE,L	1
PMZ200-V-L-028	LIMIT PLATE,R	1
PMZ200-V-L-029	Rubber,Hnager	1

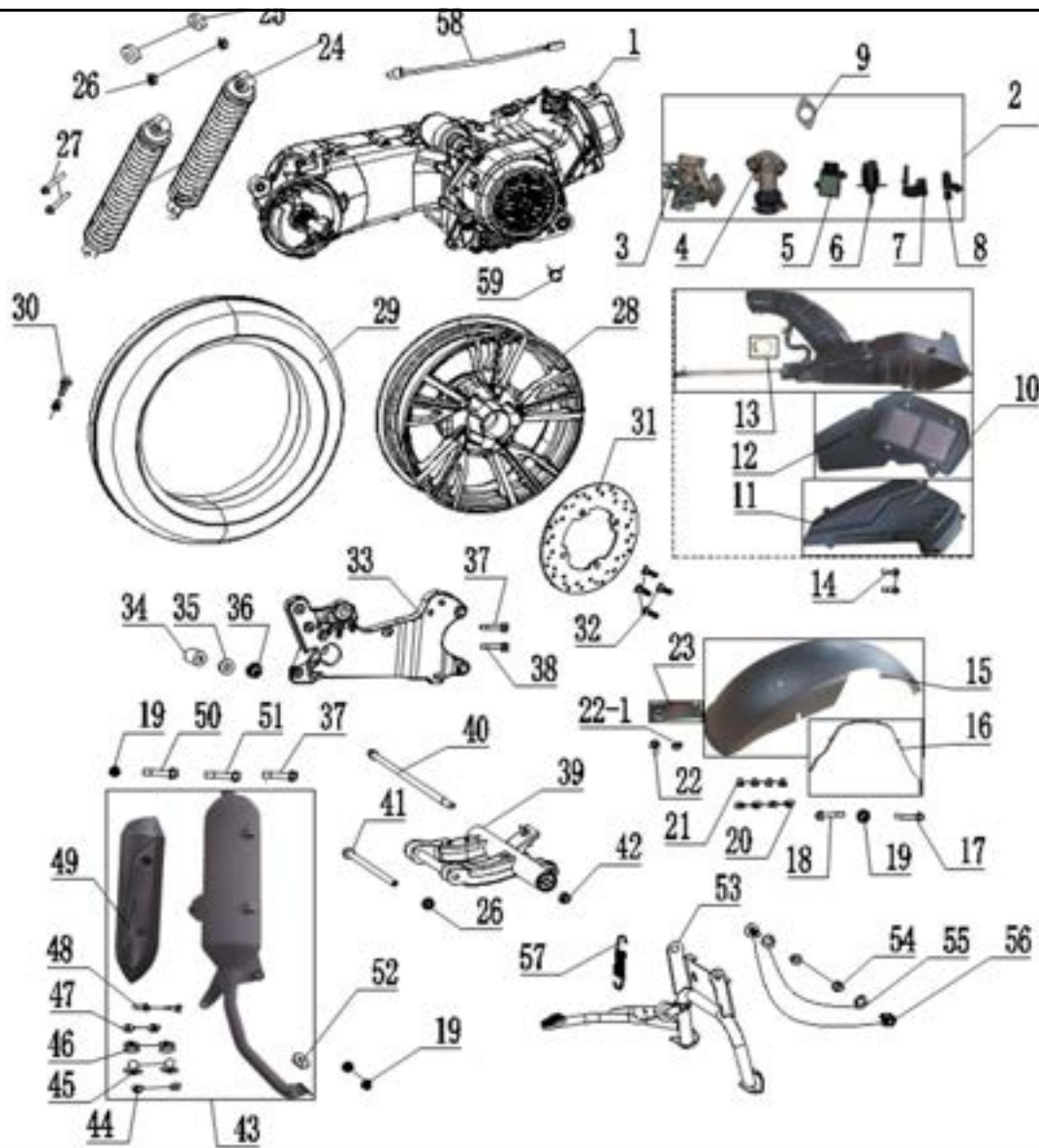

Part No.	Description	Qty per Vehicel
PMZ200-V-M-001	ENGINE ASSY	1
PMZ200-V-M-002	Throttle assy.	1
PMZ200-V-M-005	Intake-temp sensor	1
PMZ200-V-M-006	Step motor	1
PMZ200-V-M-007	Holder,injector	1
PMZ200-V-M-008	Injector	1
PMZ200-V-M-009	Anti-heat Gasket,intake	1
PMZ200-V-M-010	Air Filter Assy.	1
PMZ200-V-M-011	Cover,air cleaner	1
PMZ200-V-M-012	Element,air cleaner	1
PMZ200-V-M-013	Clamp,air cleaner	1
PMZ200-V-M-014	Bolt M6*25	2
PMZ200-V-M-015	RR fender	1
PMZ200-V-M-016	Rr bracket,rr fender	1
PMZ200-V-M-017	Bolt M8X25	1

PMZ200-V-M-018	Bolt M8X35	1
PMZ200-V-M-019	Nut M8	4
PMZ200-V-M-020	Washer,large	4
PMZ200-V-M-021	Gap nut	4
PMZ200-V-M-022	Bolt M6X12	1
PMZ200-V-M-022-1	Washer,Φ6*Φ18*1.6	1
PMZ200-V-M-023	RH bracket,rr fender	1
PMZ200-V-M-024	Rear Absorber	2
PMZ200-V-M-025	Spacer,bracket absorber	2
PMZ200-V-M-026	Lock nut M10	3
PMZ200-V-M-027	Bolt M8X30	2
PMZ200-V-M-028	RR Rim	1
PMZ200-V-M-029	RR Tire	1
PMZ200-V-M-030	VALVE RIM	1
PMZ200-V-M-031	Disc of RR Brake CBS	1
PMZ200-V-M-032	Step bolt,Disc,M8*25	4
PMZ200-V-M-033	Swing arm,engine	1
PMZ200-V-M-034	Outer bushing of connecting plate	1
PMZ200-V-M-035	Inner bushing of connecting plate	1
PMZ200-V-M-036	LOCKING NUT M16*1.5	1
PMZ200-V-M-037	Bolt M10*60*1.25	2
PMZ200-V-M-038	Bolt M10*70*1.25	1
PMZ200-V-M-039	Hanger	1
PMZ200-V-M-040	Self locking nut M12*1.25	1
PMZ200-V-M-041	Bolt M10*195	1
PMZ200-V-M-042	Axel,Hanger	1
PMZ200-V-M-043	MUFFLER ASSY,with Catalyst	

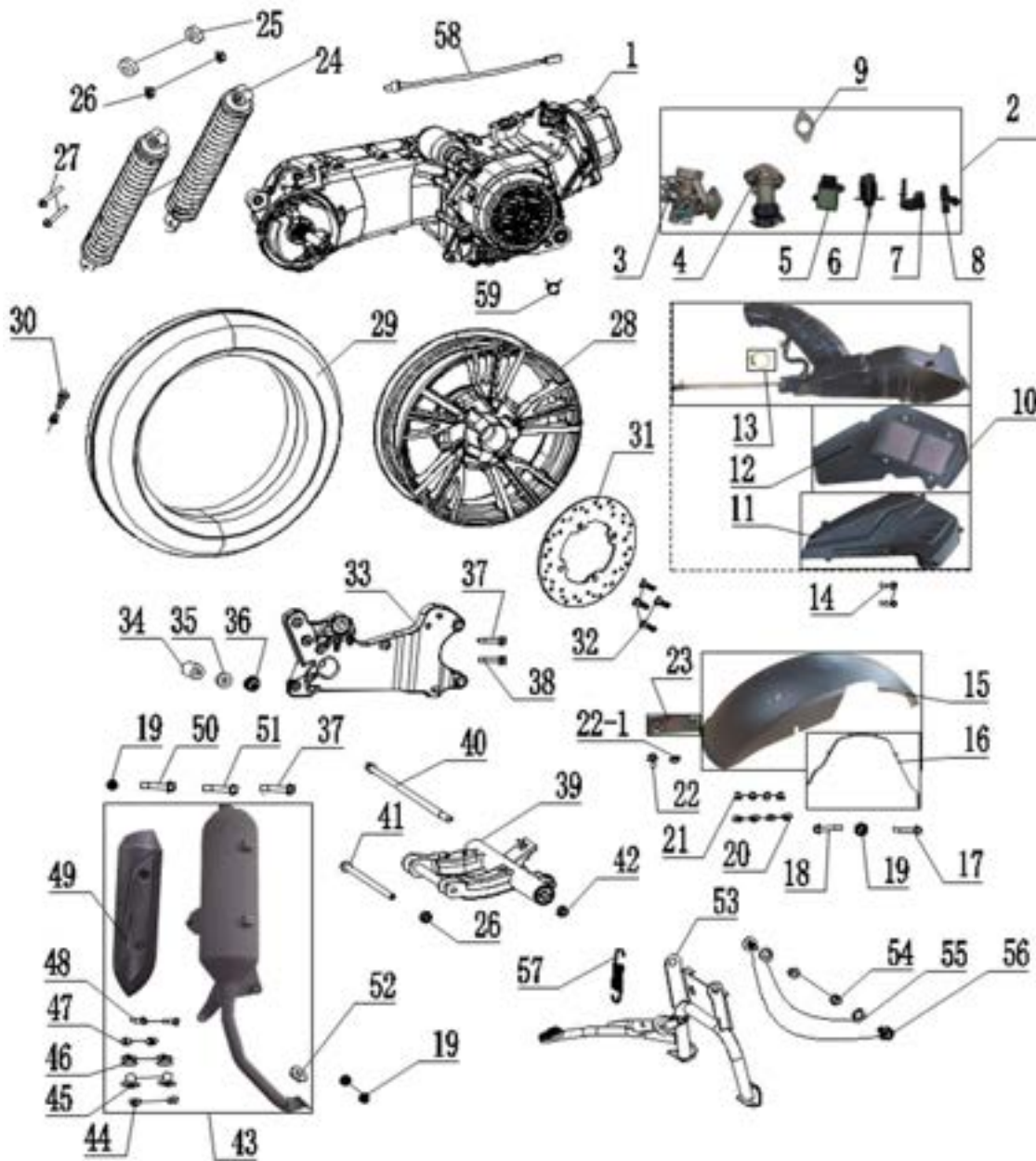

Part No.	Description	Qty per Vehicle
PMZ200-V-M-044	Anti heat washer,muffler	2
PMZ200-V-M-045	Spacer,cover,muffler	2
PMZ200-V-M-046	Rubber,Cover,muffler	2
PMZ200-V-M-047	Washer,cover,muffler	2
PMZ200-V-M-048	Bolt,cover,muffler	2
PMZ200-V-M-049	Cover,muffler	1
PMZ200-V-M-050	Bolt M8*35	1
PMZ200-V-M-051	Bolt M8*45	1
PMZ200-V-M-052	Washer,cylinder head	1
PMZ200-V-M-053	Main stand	1
PMZ200-V-M-054	Spacer,MAIN STAND	2
PMZ200-V-M-055	RUBBER,MAIN STAND	2
PMZ200-V-M-056	Bolt M10*30	2
PMZ200-V-M-057	Spring,main stand	1

PMZ200-V-M-058	Temp sensor,engine	1
PMZ200-V-M-059	Clip	1

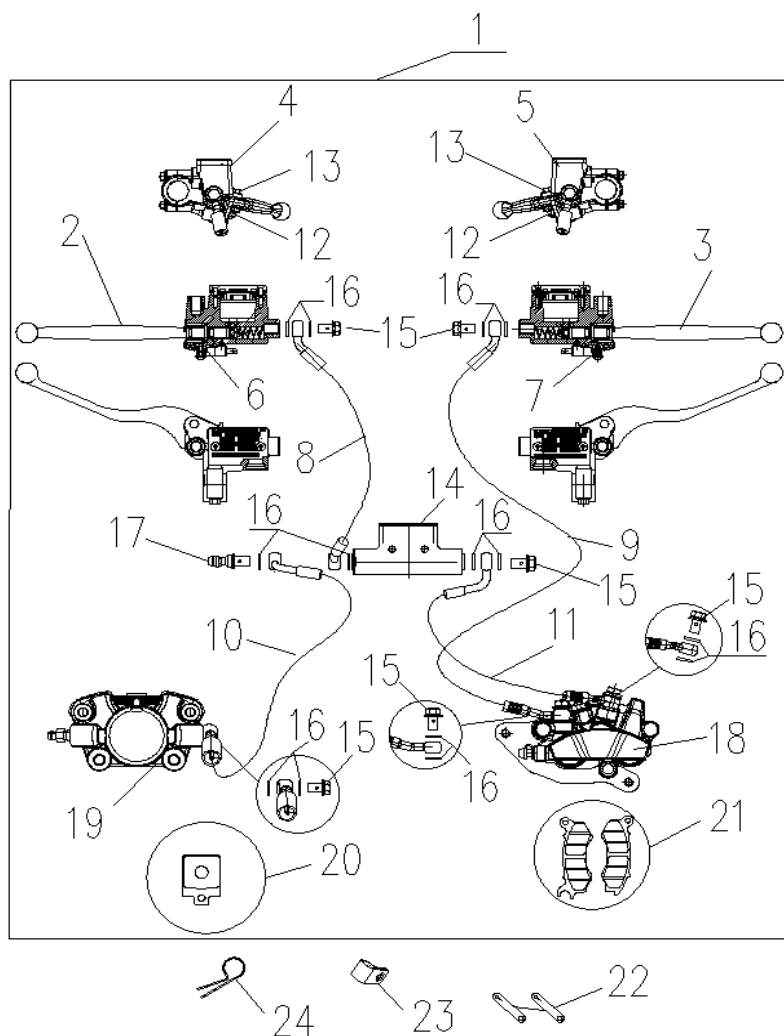

Part No.	Description	Qty per Vehicel
PMZ200-V-N-001	CBS BRAKE ASSY	1
PMZ200-V-N-002	LEVER L	1
PMZ200-V-N-003	LEVER R	1
PMZ200-V-N-004	MASTER CYLINDER PUMP RR	1
PMZ200-V-N-005	MASTER CYLINDER PUMP FR	1
PMZ200-V-N-006	SWITCH, RR BRAKE	1
PMZ200-V-N-007	SWITCH, FR BRAKE	1
PMZ200-V-N-008	RR upper brake pipe(450)	1
PMZ200-V-N-009	FR upper brake pipe(970)	1
PMZ200-V-N-010	RR lower brake pipe(1805)	1
PMZ200-V-N-011	FR lower brake pipe(720)	1
PMZ200-V-N-012	FLANGE NUT M6	2
PMZ200-V-N-013	BOLT HANDLE LEVER	2
PMZ200-V-N-014	Proportional Valve	1
PMZ200-V-N-015	Bolt,tube,brake	6

PMZ200-V-N-016	Oil Seal Gasket,BRAKE	14
PMZ200-V-N-017	Bolt,exhaust.	1
PMZ200-V-N-018	LEFT CALIPER ASSY FR	1
PMZ200-V-N-019	LEFT CALIPER ASSY RR	1
PMZ200-V-N-020	RR Brake Pad	1
PMZ200-V-N-021	FR Brake Pad	1
PMZ200-V-N-022	RUBBER TIE 2	2
PMZ200-V-N-023	BRAKE TUBE CLIP 3	2
PMZ200-V-N-024	Clip,oil tube 2	1

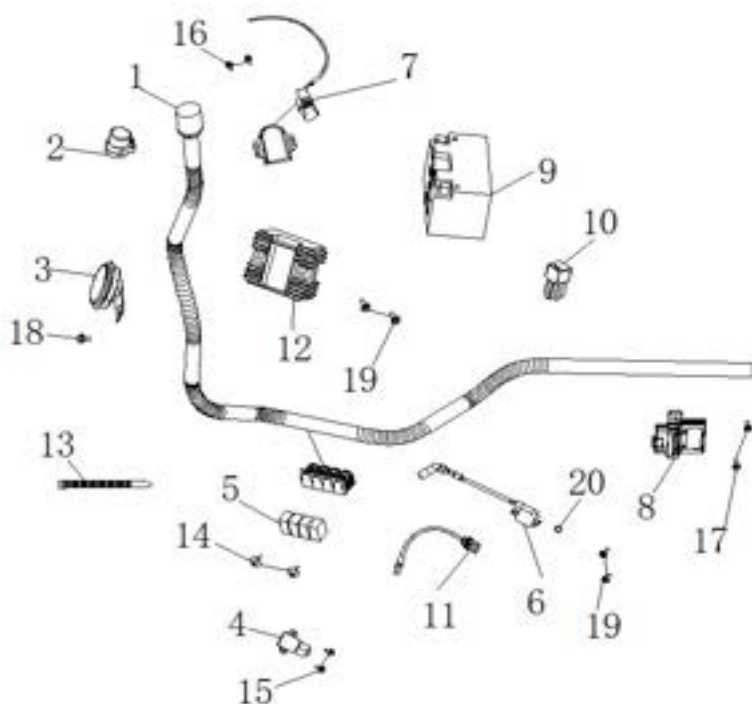

Part No.	Description	Qty per Vehicel
PMZ200-V-O-001	Main harness	1
PMZ200-V-O-002	Flasher	1
PMZ200-V-O-003	Horn	1
PMZ200-V-O-004	Side Stand Flameout Switch	1
PMZ200-V-O-005	ECU Relay	4
PMZ200-V-O-006	Igniton coil assy	1
PMZ200-V-O-007	USB charger	1
PMZ200-V-O-008	ECU	1
PMZ200-V-O-009	Battery	1
PMZ200-V-O-010	Start Relay	1
PMZ200-V-O-011	O2 sensor	1
PMZ200-V-O-012	Rectifier	1
PMZ200-V-O-013	Cable ties	11

PMZ200-V-O-014	Pan screw,M5*10	2
PMZ200-V-O-015	Hexagon socket bolt M5X16	2
PMZ200-V-O-016	Hexagon socket bolt M5X16	2
PMZ200-V-O-017	Hexagon socket bolt M6X16	2
PMZ200-V-O-018	Bolt M6X12	1
PMZ200-V-O-019	Bolt M6X20	4
PMZ200-V-O-020	Ties	12