

1. Plastic cover		
Parts No.	Discription	Qty per Vehicel
PAD50-2-A-001	big flat head bolts M6X20	2
PAD50-2-A-002	fuel tank	1
PAD50-2-A-003	big flat head bolts M6X10	2
PAD50-2-A-004	countersunk head bolt M6X8	4

PAD50-2-A-005	front cover, right	1
	front cover, right-black	
	front cover, right-red	
	front cover, right-green	
	front cover, right-yellow	
PAD50-2-A-006	rear cove, right	1
PAD50-2-A-007	chest protector	1
PAD50-2-A-008	seat	1
PAD50-2-A-009	chain cover	1
PAD50-2-A-010	rubber plain washer	8
PAD50-2-A-011	big flat head bolts M6X10	8
PAD50-2-A-012	front fender	1
	front fender-black	
	front fender-red	
	front fender-green	
	front fender-yellow	
PAD50-2-A-013	big flat head bolts M6X16	8
PAD50-2-A-014	front cover, left	1
	front cover, left-black	
	front cover, left-red	
	front cover, left-green	
	front cover, left-yellow	
PAD50-2-A-015	small flat head bolts M6X16	6
PAD50-2-A-016	rear cove, left	1
PAD50-2-A-017	rear molding	1
	rear molding-black	
	rear molding-red	
	rear molding-green	
	rear molding-yellow	

PAD50-2-A-018	Fender bracket	1
PAD50-2-A-019	bolt	2

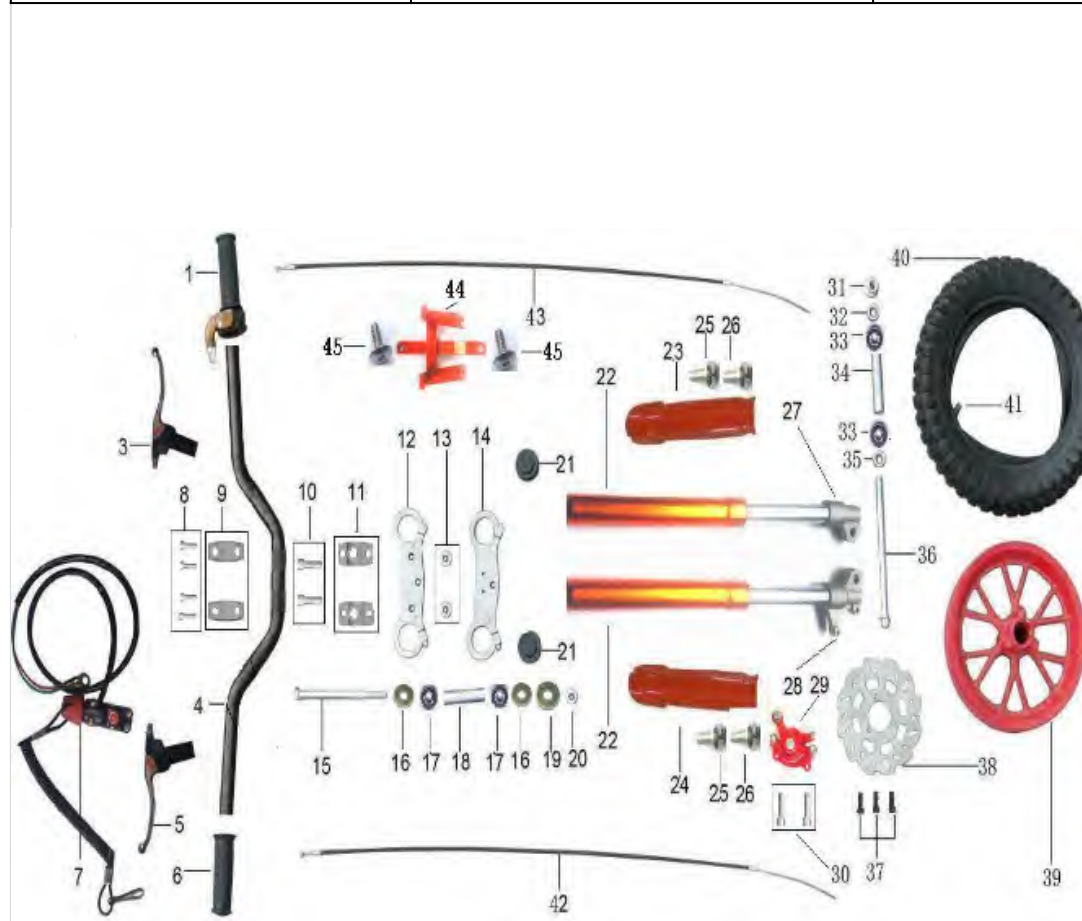

2. Front wheel 前轮

Parts No.	Discription	Qty per Vehicel
PAD50-2-B-001	right handle grip	1
PAD50-2-B-003	right handle	1
PAD50-2-B-004	handle bar	1

PAD50-2-B-005	left handle	1
PAD50-2-B-006	left handle grip	1
PAD50-2-B-007	switch stop	1
PAD50-2-B-008	bolt	4
PAD50-2-B-009	bracket,top riser	2
PAD50-2-B-010	bolt	2
PAD50-2-B-011	bracket,bottom riser	2
PAD50-2-B-012	triple tree, top	1
PAD50-2-B-013	nut	2
PAD50-2-B-014	triple tree, bottom	1
PAD50-2-B-015	direction turning	1
PAD50-2-B-016	flat washer	2
PAD50-2-B-017	bearing	2
PAD50-2-B-018	inner sleeve $\Phi 11 \times \Phi 16 \times 87 \text{mm}$	1
PAD50-2-B-019	flat washer	1
PAD50-2-B-020	nut	1
PAD50-2-B-021	rubber plug	2
PAD50-2-B-022	front fork	2
PAD50-2-B-023	front protection,right	1
PAD50-2-B-024	front protection ,left	1
PAD50-2-B-025	bolt	2
PAD50-2-B-026	bolt	2
PAD50-2-B-027	right aluminum head	1
PAD50-2-B-028	left aluminum head	1
PAD50-2-B-029	front brake	1
PAD50-2-B-030	bolt	2
PAD50-2-B-031	nut	1
PAD50-2-B-032	sleeve $\Phi 12.2 \times \Phi 16 \times 6.5 \text{mm}$	1



3.Frame 车架

Parts No.	Discription	Qty per Vehicel
PAD50-2-C-001	frame	1
PAD50-2-C-002	oil pipe	1
PAD50-2-C-003	filter	1
PAD50-2-C-004	muffler	1
PAD50-2-C-005	iron tablets	1
PAD50-2-C-006	double rubber mat	2
PAD50-2-C-007	clamp	1
PAD50-2-C-008	washer of clamp	1
PAD50-2-C-009	ignition key	1
PAD50-2-C-010	engine	1
PAD50-2-C-010-01	engine bracket	1

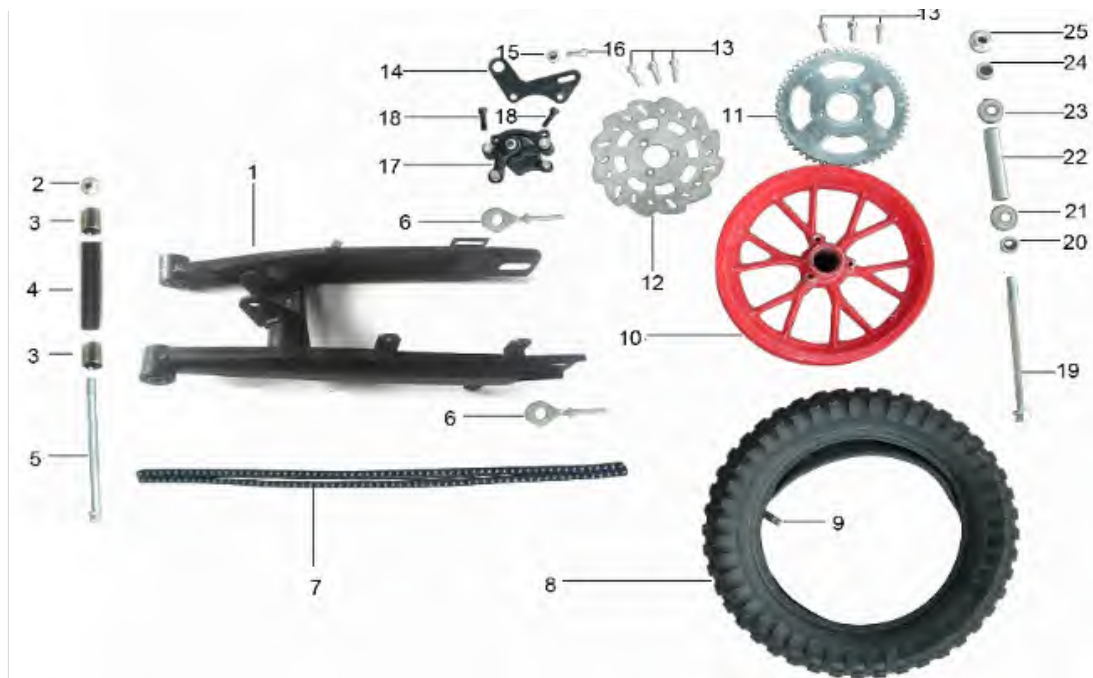

4. Rear wheel 后轮

Parts No.	Discription	Qty per Vehicel
PAD50-2-D-001	swing arm	1
PAD50-2-D-002	nut	1
PAD50-2-D-003	buffer sleeve	2
PAD50-2-D-004	inner sleeveΦ10.5XΦ16X80.5mm	1
PAD50-2-D-005	bolt	1
PAD50-2-D-006	chain adjuster	2
PAD50-2-D-007	chain	1
PAD50-2-D-008	rear tyre	1
PAD50-2-D-009	Inner tube	1
PAD50-2-D-010	rear rim	1
PAD50-2-D-011	big sprocket	1

PAD50-2-D-012	rear bdisc brake	1
PAD50-2-D-013	screw	3
PAD50-2-D-014	braket	1
PAD50-2-D-015	nut	1
PAD50-2-D-016	screw	1
PAD50-2-D-017	rear brake	1
PAD50-2-D-018	screw	2
PAD50-2-D-019	bolt	1
PAD50-2-D-020	axle $\Phi 12.2 \times \Phi 16 \times 12 \text{mm}$	1
PAD50-2-D-021	bearing 1	1
PAD50-2-D-022	axle $\Phi 12.2 \times \Phi 16 \times 80.5 \text{mm}$	1
PAD50-2-D-023	bearing 2	1
PAD50-2-D-024	axle $\Phi 12.2 \times \Phi 16 \times 8 \text{mm}$	1
PAD50-2-D-025	nut	1