



Parts No.	Description	Qty per Vehicle
		
PMZ150-19-A-1	frame	1
PMZ150-19-A-2	nut	1
PMZ150-19-A-3	axle	1
PMZ150-19-A-4	hanger	1
PMZ150-19-A-5	bolt	2
PMZ150-19-A-6	nut	2
PMZ150-19-A-7	bushing	1
PMZ150-19-A-8	spring	2
PMZ150-19-A-9	front footpeg pin	2
PMZ150-19-A-10	pin	2
PMZ150-19-A-11	front footpeg	2
PMZ150-19-A-12	bolt	3
PMZ150-19-A-13	HOLDER,BATTERY	1

		
PMZ150-19-B-1	engine	1
PMZ150-19-B-2	connecting plate	1
PMZ150-19-B-3	CARBURETOR	1
PMZ150-19-B-4	Rear Brake Shoe Set	2
PMZ150-19-B-5	Return Spring, Rear Brake Shoe	2
PMZ150-19-B-6	bear	1
PMZ150-19-B-7	oil seal	1
PMZ150-19-B-8	bush	1
PMZ150-19-B-9	clip	1

		
PMZ150-19-C-1	rear tire	1
PMZ150-19-C-2	rear rim	1
PMZ150-19-C-3	rear hub	1
PMZ150-19-C-4	nut	4
PMZ150-19-C-5	bolt	4

		
PMZ150-19-D-1	bracket,headlight	1
PMZ150-19-D-2	headlight cover	1
PMZ150-19-D-3	front shield install frame	1
PMZ150-19-D-4	bolt	3
PMZ150-19-D-5	rubber pad	3
PMZ150-19-D-6	bolt	2
PMZ150-19-D-7	front turning	2
PMZ150-19-D-8	Bulb, Headlight	2

		
PMZ150-19-E-1	bolt	1
PMZ150-19-E-2	kick stand spring	1
PMZ150-19-E-3	kick stand	1

		
---	--	--

Parts No.	Description	Qty per Vehicle
PMZ150-19-F-1	LATTER GUARD SHIELD	1
PMZ150-19-F-2	rear shield	1
PMZ150-19-F-3	bolt	8
PMZ150-19-F-4	nut	8



PMZ150-19-G-1	front fender	1
PMZ150-19-G-2	bolt	3
PMZ150-19-G-3	nut	1
PMZ150-19-G-4	front shock (left)	1
PMZ150-19-G-5	front shock (right)	1
PMZ150-19-G-6	connecting plate	1
PMZ150-19-G-7	bolt	4
PMZ150-19-G-8	steering stem	1
PMZ150-19-G-9	bearing	1
PMZ150-19-G-10	steering stem cover	1
PMZ150-19-G-11	bolt	2



PMZ150-19-H-1	handlebar	1
PMZ150-19-H-2	LEFT COMBINATION SWITCH	1
PMZ150-19-H-3	right COMBINATION SWITCH	1
PMZ150-19-H-4	GRIP	1
PMZ150-19-H-5	THROTTLE GRIP	1
PMZ150-19-H-6	handle guide	1
PMZ150-19-H-7	handlebar lock	2
PMZ150-19-H-8	nut	1
PMZ150-19-H-9	SPRING WASHER	1
PMZ150-19-H-10	bushing	1
PMZ150-19-H-11	bolt	1
PMZ150-19-H-12	speedometer	1
PMZ150-19-H-13	bolt	2
PMZ150-19-H-14	rear mirror	2

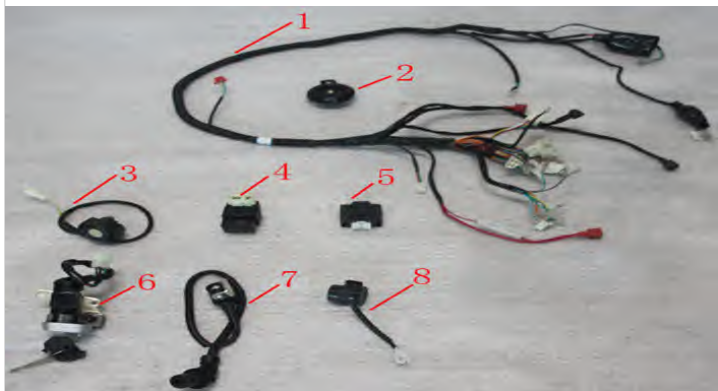

PMZ150-19-I-1	MAIN WIRE	1
PMZ150-19-I-2	HORN	1
PMZ150-19-I-3	STARTER RELAY	1
PMZ150-19-I-4	CDI	1
PMZ150-19-I-5	REGULATOR	1
PMZ150-19-I-6	SWITCH ASSY,IGNITION	1
PMZ150-19-I-7	IGNITION COIL	1
PMZ150-19-I-8	RELAY ASSY,TUNIGNAL	1



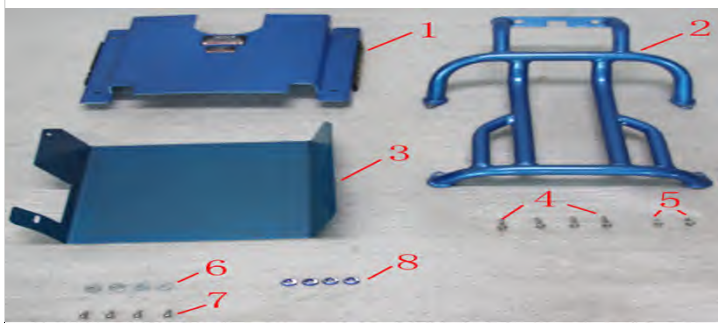

PMZ150-19-J-1	rear brake cable	1
PMZ150-19-J-2	THROTTLE CABLE	1
PMZ150-19-J-3	speedo cable	1
PMZ150-19-J-4	speed senser	1
PMZ150-19-J-5	cable clamp	1



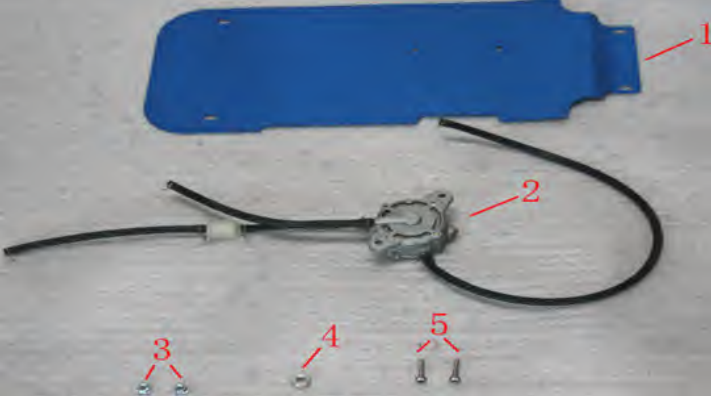

PMZ150-19-K-1	FUEL TANK COVER	1
PMZ150-19-K-2	FUEL TANK BRACKET	1
PMZ150-19-K-3	COVER UNDER FUEL TANK	1
PMZ150-19-K-4	bolt	4
PMZ150-19-K-5	bolt	2
PMZ150-19-K-6	SPRING WASHER	4
PMZ150-19-K-7	bolt	4
PMZ150-19-K-8	nut	4





Parts No.	Description	Qty per Vehicel
		
PMZ150-19-L-1	cover under seat	1
PMZ150-19-L-2	oil pump	1
PMZ150-19-L-3	nut	1
PMZ150-19-L-4	bushing	1
PMZ150-19-L-5	bolt	2

		
PMZ150-19-M-1	front tire	1
PMZ150-19-M-2	front rim	1
PMZ150-19-M-3	front brake disc	1
PMZ150-19-M-4	bushing	1
PMZ150-19-M-5	nut	1
PMZ150-19-M-6	front axle	1
PMZ150-19-M-7	front brake	1
PMZ150-19-M-8	Master cylinder	1
PMZ150-19-M-9	brake lever	1
PMZ150-19-M-10	Brake Line	1
PMZ150-19-M-11	Brake Caliper	1
PMZ150-19-M-12	Brake Pad	2
PMZ150-19-M-13	bracket	1
PMZ150-19-M-14	bolt	2

		
PMZ150-19-N-1	rear turning light	2
PMZ150-19-N-2	rear shock	2
PMZ150-19-N-3	rear light	1

		
PMZ150-19-O-1	muffler	1
PMZ150-19-O-2	paper pad	1
PMZ150-19-O-3	exhaust	1
PMZ150-19-O-4	clip	2
PMZ150-19-O-5	bolt	3
PMZ150-19-O-6	bolt	2

		
PMZ150-19-P-1	fuel tank	1
PMZ150-19-P-2	GAS SENSOR	1

		
PMZ150-19-Q-1	seat	1
PMZ150-19-Q-2	intake manifold	1
PMZ150-19-Q-3	air filter	1
PMZ150-19-Q-4	clamp	2
PMZ150-19-Q-5	FIXED BUCKLE	2
PMZ150-19-Q-6	air filter bracket	1
PMZ150-19-Q-7	bolt	2
PMZ150-19-Q-8	nut	2

Parts No.	Description	Qty per Vehicel
PMZ150-19-R-1	tool	1
PMZ150-19-R-2	buttery	1
PMZ150-19-R-3	electrolyte	1
PMZ150-19-R-4	bolt	2