

NO.	ICEBEAR Part NO.	Chinese Name	Description	QTY
-----	------------------	--------------	-------------	-----

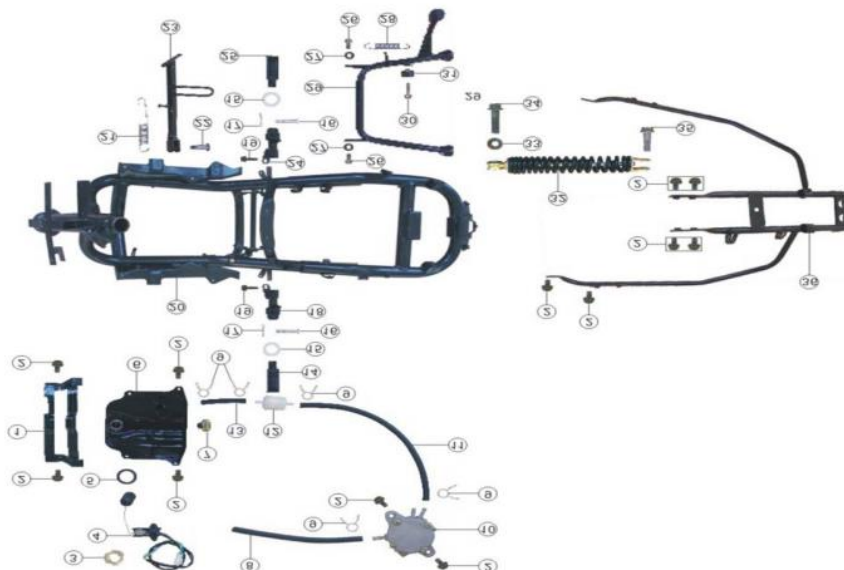

1	PMZ150-5N-A-001	油箱支架	BRACKET FUEL TANK	1
2	PMZ150-5N-A-002	螺栓	HEX FLANGE BULT M6*12	1
3	PMZ150-5N-A-003	装饰圈	COVER,FVSENSOR	1
4	PMZ150-5N-A-004	油量传感器	FUEI SENSOR	1
5	PMZ150-5N-A-005	油封	SEAL GASKET,FUEL SENSOR	1
6	PMZ150-5N-A-006	油箱	FUEL TANK	1
7	PMZ150-5N-A-007	油箱	FUEL TANK	1
8	PMZ150-5N-A-008	油管	FUEL TUBE I	1
9	PMZ150-5N-A-009	卡箍	ELASTICITY FASTENER	1
10	PMZ150-5N-A-010	油泵	FUEL LOW-TENSIONSWITCH	1
11	PMZ150-5N-A-011	油管	FUEL TUBE II	1
12	PMZ150-5N-A-012	燃油过滤器	FUEL FILTER	1
13	PMZ150-5N-A-013	油管	FUEL TUBE III	1
14	PMZ150-5N-A-014	右脚蹬	R.FOOTREST	1
15	PMZ150-5N-A-015	垫圈	GASKET	1
16	PMZ150-5N-A-016	开口销	SHAFT,FOOTREST	1
17	PMZ150-5N-A-017	开口销	SPLIT,PIN	1
18	PMZ150-5N-A-018	支架	BRACKET,R.FOOTREST	1
19	PMZ150-5N-A-019	螺栓	HEX FLANGE BULT M6*16	1
20	PMZ150-5N-A-020	车架	MAIN FRAME	1
21	PMZ150-5N-A-021	单撑弹簧	SPRING,SIDE STAND	1
22	PMZ150-5N-A-022	单撑螺栓	BULT,SIDE STAND	1
23	PMZ150-5N-A-023	单撑	SIDE STAND	1
24	PMZ150-5N-A-024	脚蹬左支架	BRACKET,L. FOOTREST	1
25	PMZ150-5N-A-025	左脚蹬	L. FOOTREST	1
26	PMZ150-5N-A-026	螺栓	BULT,MAIN STAND M10*25	1
27	PMZ150-5N-A-027	橡胶圈	BUSH,MAIN STAND	1
28	PMZ150-5N-A-028	单撑弹簧	SPRING,MAIN STAND	1
29	PMZ150-5N-A-029	中撑	MAIN STAND	1
30	PMZ150-5N-A-030	螺栓	HEX FLANGE BULT M6*30	1
31	PMZ150-5N-A-031	橡胶圈	CUSHION RUBBER,MAIN STAND	1
32	PMZ150-5N-A-032	前减	RR.SHOCK ABSORBER	1

33	PMZ150-5N-A-033	螺母	LOCK NUT M10	1
34	PMZ150-5N-A-034	螺栓	HEX FLANGE BULT M10*40	1
35	PMZ150-5N-A-035	螺栓	HEX FLANGE BULT M8*32	1
36	PMZ150-5N-A-036	后泥板支架	BRACKET,REAR FENDER	1

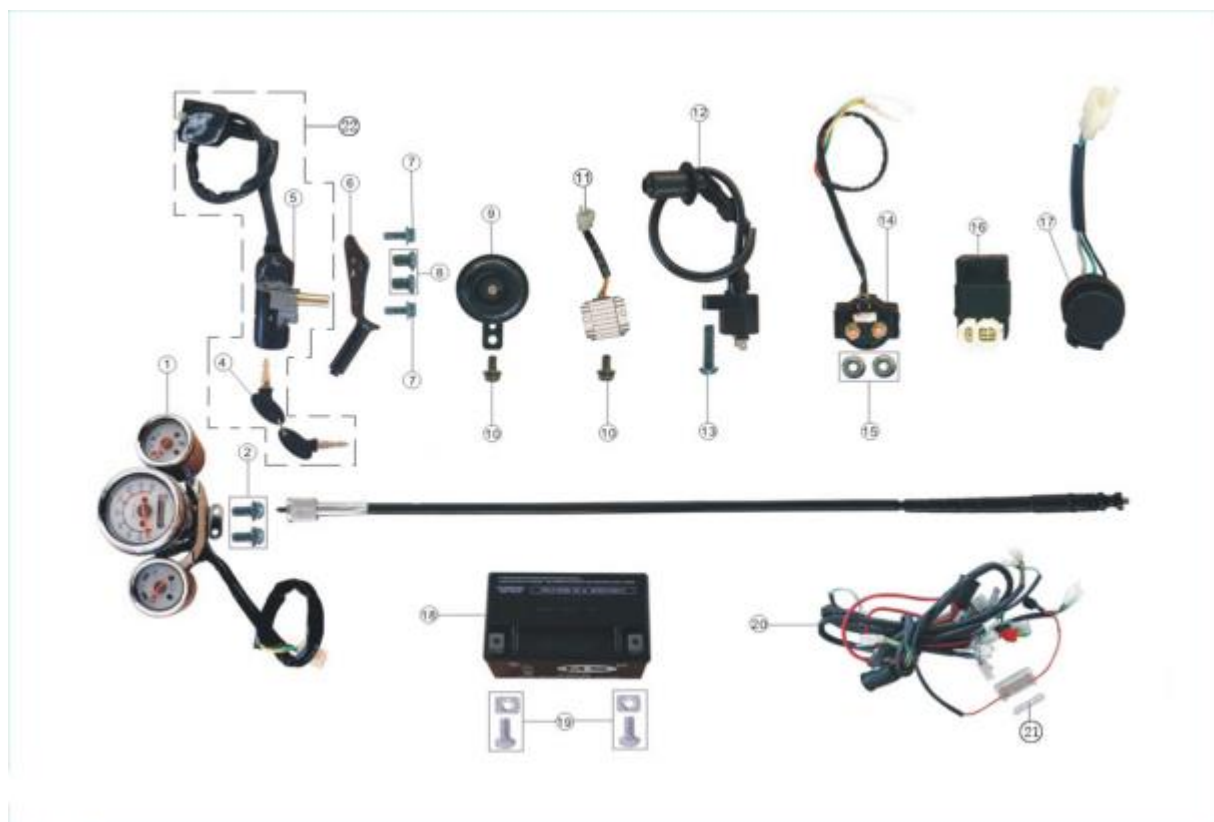

1	PMZ150-5N-B-001	里程表	SPEEDOMETER	1
2	PMZ150-5N-B-002	螺丝	CRISSCROSS BUIT M4*12	1
3	PMZ150-5N-B-003	里程线	SPEEDOMETER CABLE	1
4	PMZ150-5N-B-004	钥匙	KEY	1
5	PMZ150-5N-B-005	电门锁	IGNITION SWITCH	1
6	PMZ150-5N-B-006	电门锁支架	BRACKET IGNITION SWITCH	1
7	PMZ150-5N-B-007	螺栓	HEX FLANGE BULT M6*16	1
8	PMZ150-5N-B-008	螺栓	BULT,IGNITION SWITCH	1
9	PMZ150-5N-B-009	喇叭	HORN	1
10	PMZ150-5N-B-010	螺栓	HEX FLANGE BULT M6*12	1
11	PMZ150-5N-B-011	稳压器	RECTIFIER	1
12	PMZ150-5N-B-012	高压泵	IGNITION COIL COMP	1
13	PMZ150-5N-B-013	螺栓	CRISSCROSS BUIT M5*20	1
14	PMZ150-5N-B-014	启动继电器	RELAY	1
15	PMZ150-5N-B-015	螺栓	HEX FLANGE BULT M6	1
16	PMZ150-5N-B-016	点火器	C.D.I	1
17	PMZ150-5N-B-017	启动继电器	SINGING SPARKING RELAY	1
18	PMZ150-5N-B-018	电瓶	BATTERY	1
19	PMZ150-5N-B-019	电瓶螺栓	BULT&NUT,BATTERY	1
20	PMZ150-5N-B-020	导线	HARNESS WIRE	1
21	PMZ150-5N-B-021	二极管	RUSE	1

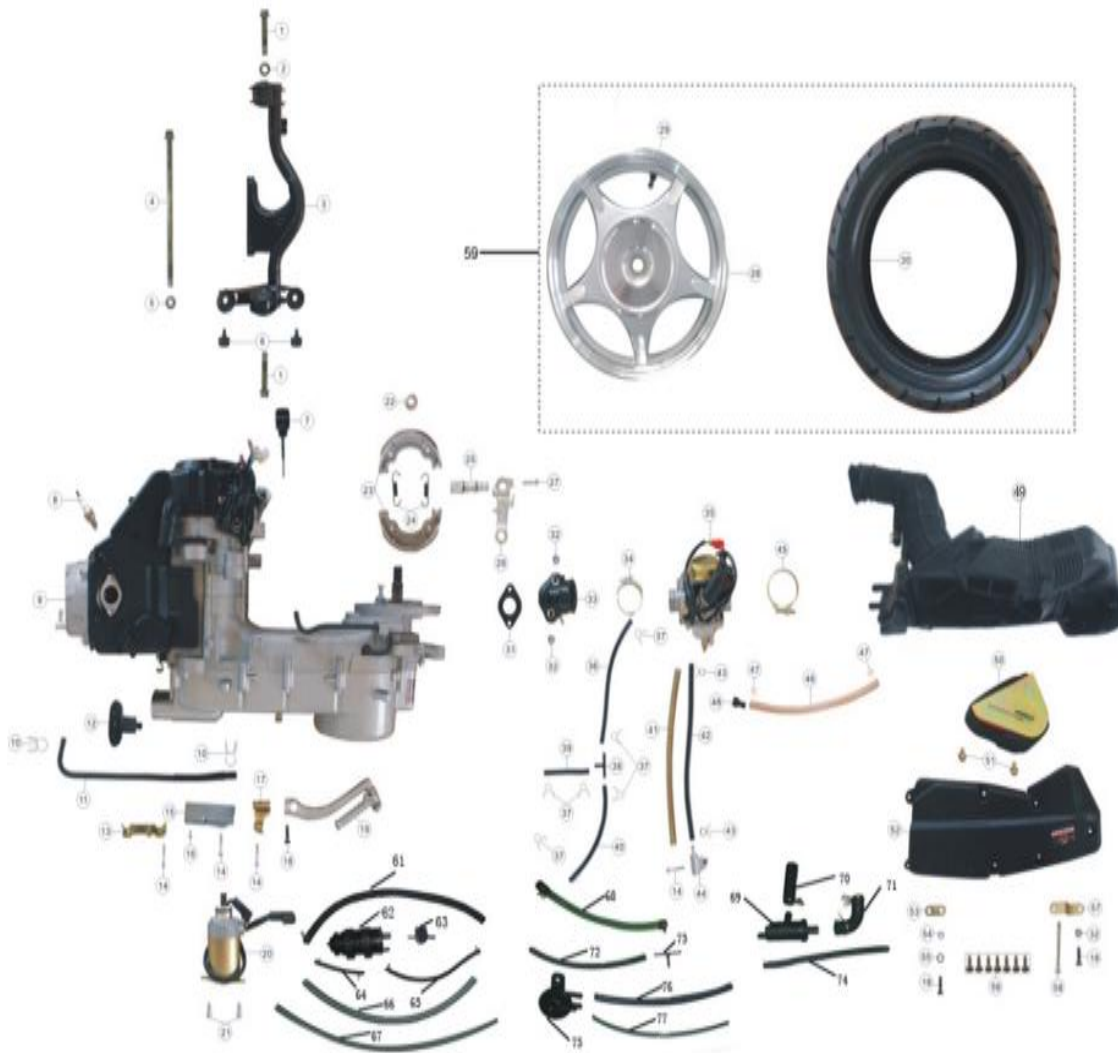

1	PMZ150-5N-C-001	螺栓	HEX FLANGE BULT M10*55	1
2	PMZ150-5N-C-002	橡胶垫	BUSH	1
3	PMZ150-5N-C-003	发动机支架	SWING BRACKET,ENGINE	1
4	PMZ150-5N-C-004	后平叉支架	SHAFT,SWING BRACKET	1
5	PMZ150-5N-C-005	自锁螺母	LOCK NUT M10	1
6	PMZ150-5N-C-006	橡胶圈	RUBBER,SWING BRACKET	1
7	PMZ150-5N-C-007	机油尺	GAVGE,UIL SEAL	1
8	PMZ150-5N-C-008	螺栓	PLUG,SPARK	1
9	PMZ150-5N-C-009	发动机	ENGINE ASSY	1
10	PMZ150-5N-C-010	卡箍	FASTENER,WASTE PIPE,GEAR BOX	1
11	PMZ150-5N-C-011	螺栓	nut,GRAR BOX	1
12	PMZ150-5N-C-012	管子	FILTER,CUI.BOX	1
13	PMZ150-5N-C-013	弹簧垫	CLIP,DRAIN TUBE	1
14	PMZ150-5N-C-014	螺栓	BULT M6*40	1
15	PMZ150-5N-C-015	中撑螺栓	MAIN STAND DEAD BLOCK	1
16	PMZ150-5N-C-016	螺栓	BULT, M6*12	1
17	PMZ150-5N-C-017	卡扣	CLIP,CABLE, RR.BRAKE	1
18	PMZ150-5N-C-018	螺栓	HEX FLANGE BULT M6*22	1
19	PMZ150-5N-C-019	启动踏杆	LEVER,ASSY,KICK STARTER	1
20	PMZ150-5N-C-020	启动杆	STARTER	1

21	PMZ150-5N-C-021	螺栓	BULT M6*16	1
22	PMZ150-5N-C-022	锁紧螺栓	LOCK NUT M16	1
23	PMZ150-5N-C-023	刹车开关	BRAKE BLOCK ASSY	1
24	PMZ150-5N-C-024	弹簧	SPRING	1
25	PMZ150-5N-C-025	凸轴	CAMSHAFT,RR.BRAKE	1
26	PMZ150-5N-C-026	后平叉支架	SWING ARM,RR.BRAKE	1
27	PMZ150-5N-C-027	螺栓	BULT M6*32	1
28	PMZ150-5N-C-028	后轮钢圈	REAR RIM	1
29	PMZ150-5N-C-029	气门嘴	AIR VALVE	1
30	PMZ150-5N-C-030	后轮胎	REAR TYPE 120/70-12	1
31	PMZ150-5N-C-031	橡胶垫圈	INSULATOR	1
32	PMZ150-5N-C-032	螺栓	HEX FLANGE NUT M6	1
33	PMZ150-5N-C-033	油管	ASSY,PIPE IN	1
34	PMZ150-5N-C-034	卡扣	FASTENER I	1
35	PMZ150-5N-C-035	化油器	CARBURETOY ASSY	1
36	PMZ150-5N-C-036	油管	PIPE IN I	1
37	PMZ150-5N-C-037	卡扣	FASTENER,PIPE IN	1
38	PMZ150-5N-C-038	油管	TRIPLE TUBE	1
39	PMZ150-5N-C-039	油管	PIPE IN II	1
40	PMZ150-5N-C-040	油管	PIPE IN III	1
41	PMZ150-5N-C-041	弹簧	SPRING, DRAIN TUBE	1
42	PMZ150-5N-C-042	油管	PIPE IN III	1
43	PMZ150-5N-C-043	油管	PIPE IN III	1
44	PMZ150-5N-C-044	油管	PIPE IN III	1
45	PMZ150-5N-C-045	卡扣	FASTENER II	1
46	PMZ150-5N-C-046	空滤卡扣	WASTE PIPE,AIRCLEANER	1
47	PMZ150-5N-C-047	空滤卡扣	FASTENER,WASTE PIPE,AIR CLEANER	1
48	PMZ150-5N-C-048	空滤管	PLUG,WASTE PIPE,AIR CLEANER	1
49	PMZ150-5N-C-049	空滤	AIR CLEANER	1
50	PMZ150-5N-C-050	空滤扣	AIR CLEANER CORE	1
51	PMZ150-5N-C-051	螺栓	BULT,AIR CLEANER CORE	1
52	PMZ150-5N-C-052	空滤支架	BRACKET,COVER,AIR CLEANER	1
53	PMZ150-5N-C-053	空滤扣	AIR CLEANER I	1
54	PMZ150-5N-C-054	螺栓	NUT M6	1
55	PMZ150-5N-C-055	卡扣	GASKET Ø6	1
56	PMZ150-5N-C-056	螺栓	SCREW,TAPPING,ST4.8*16	1
57	PMZ150-5N-C-057	支架	BRACKET,AIR CLEANER II	1
58	PMZ150-5N-C-058	螺栓	BULT M6*65	1
59	PMZ150-5N-C-059	后轮胎	rear tire	1
		后轮钢圈	rim	1
61	PMZ150-5N-C-060	进气阀	AIR FILTER CONNECTION TUBE	1
62	PMZ150-5N-C-061	二次进气	CARBON TANK	1
63	PMZ150-5N-C-062	二次进气	BALANCE VALVE	1
64	PMZ150-5N-C-063	油管	PIPE IN	1
65	PMZ150-5N-C-064	油管	PIPE IN	1
66	PMZ150-5N-C-065	油管	PIPE IN	1
67	PMZ150-5N-C-066	油管	PIPE IN	1
68	PMZ150-5N-C-067	油管	PIPE IN	1

69	PMZ150-5N-C-068	空滤接头	OIL SEPARATOR	1
70	PMZ150-5N-C-069	空滤接头	OIL SEPARATOR CONNECT AIR FILTER	1
71	PMZ150-5N-C-070	空滤吸风管	OIL SEPARATOR CONNECTION CYLINDER HE	1
72	PMZ150-5N-C-071	油管	PIPE IN	1
73	PMZ150-5N-C-072	三通	THREE-PASS PIPE	1
74	PMZ150-5N-C-073	油管	PIPE IN	1
75	PMZ150-5N-C-074	二次进气阀	ONE-WAY VALVE	1
76	PMZ150-5N-C-075	油管	PIPE IN	1
77	PMZ150-5N-C-076	油管	PIPE IN	1



1	PMZ150-5N-D-001	前泥板后部	FRONT FENDER, REAR PART	1
2	PMZ150-5N-D-002	螺栓	HEX FLANG BULT M6*8	1
3	PMZ150-5N-D-003	螺栓	HEX FLANG BULT M6*16	1
4	PMZ150-5N-D-004	螺栓	HEX FLANG NUT M5	1
5	PMZ150-5N-D-005	反射镜片	FR.SIDE REFLECTOR	1
6	PMZ150-5N-D-006	前泥板前部	FORWARD,FRFENDER	1
7	PMZ150-5N-D-007	前泥板装饰罩	ADORNMENT, FORWARD, FRFENDER	1
8	PMZ150-5N-D-008	螺栓	SCREW TAPPING,ST4.2*12	1
9	PMZ150-5N-D-009	螺丝	FLAKE	1

10	PMZ150-5N-D-010	螺丝	SCREW TAPPING,ST4.8*16	1
11	PMZ150-5N-D-011	面板	FRONT PANEL	1
12	PMZ150-5N-D-012	螺丝	SCREW TAPPING,ST4.0*12	1
13	PMZ150-5N-D-013	螺丝	GASKET	1
14	PMZ150-5N-D-014	前面板装饰罩	DECORATLVE COVER,FRONT PANEL	1
15	PMZ150-5N-D-015	螺栓	FLAKE WITH NUT M6	1
16	PMZ150-5N-D-016	螺栓	CRISSCROSS BULT M6*12	1
17	PMZ150-5N-D-017	螺栓	CRISSCROSS BALL-SHAPE-BULT M6*16	1
18	PMZ150-5N-D-018	前装饰罩	FORWARD,VPPER DECORATE	1
19	PMZ150-5N-D-019	后装饰罩	BACKWARD,VPPER DECORATE	1
20	PMZ150-5N-D-020	车架底板	BOTTOM COVER	1
21	PMZ150-5N-D-021	螺栓	HEX FLANG BULT M6*12	1
22	PMZ150-5N-D-022	螺栓	GASKET Ø6	1
23	PMZ150-5N-D-023	前护罩上部	CPPER INBOARD COVER	1
24	PMZ150-5N-D-024	螺栓	CRISSCROSS BULT M6*20	1
25	PMZ150-5N-D-025	号码盖	OBSERVE COVER,VIN#	1
26	PMZ150-5N-D-026	前护罩下部	LOWER INBOARD COVER	1
27	PMZ150-5N-D-027	注油口盖	COVER,GASTANK I	1
28	PMZ150-5N-D-028	注油口盖支架	BRACKET,COVER,GASTANK	1
29	PMZ150-5N-D-029	注油口锁	LOCK,COVER,GASTANK	1
30	PMZ150-5N-D-030	卡扣	CLIP,LOCK	1
31	PMZ150-5N-D-031	右边条	R.PROTECTING BAR	1
32	PMZ150-5N-D-032	左边条	L.PROTECTING BAR	1
33	PMZ150-5N-D-033	脚踏板	FOOTREST I	1
34	PMZ150-5N-D-034	右侧盖	R.RR.BOARDING	1
35	PMZ150-5N-D-035	左侧盖	L.RR.BOARDING	1
36	PMZ150-5N-D-036	油箱盖板	COVER,GASTANK II	1
37	PMZ150-5N-D-037	边缘反射器	RR.SIDE REFLECTOR	1
38	PMZ150-5N-D-038	螺栓	HEX FLANG NUT M6	1
39	PMZ150-5N-D-039	螺栓	GASKET Ø6	1
40	PMZ150-5N-D-040	电瓶盖	COVER,BATTERY	1
41	PMZ150-5N-D-041	内盖	INNER COVER SUNDRIS BOX	1
42	PMZ150-5N-D-042	座桶	SUNDRIS BOX	1
43	PMZ150-5N-D-043	化油器盖板	OBSERVE COVER,CARBURETOR	1
44	PMZ150-5N-D-044	坐垫支架	BRACKET,GEAT	1
45	PMZ150-5N-D-045	坐垫支架	FIXING-BOARD,SEAT	1
46	PMZ150-5N-D-046	螺栓	BOLT M6*80	1
47	PMZ150-5N-D-047	坐垫	SEAT	1
48	PMZ150-5N-D-048	螺栓	CAPE NUT M6	1
49	PMZ150-5N-D-049	坐垫锁	FIXING BOARD,SEAT LOCK	1
50	PMZ150-5N-D-050	螺栓	HEX FLANG BULT M6*20	1
51	PMZ150-5N-D-051	右装饰板	R. RR. DECORATIVE SHEET	1
52	PMZ150-5N-D-052	左装饰板	L. RR. DECORATIVE SHEET	1
53	PMZ150-5N-D-053	机油口盖	OBSERVE COVER,AIPFILTER	1
54	PMZ150-5N-D-054	坐垫拉线	CABLE,SEAT	1
55	PMZ150-5N-D-055	卡扣	CLIP,LOCK,SEAT	1
56	PMZ150-5N-D-056	坐垫锁	LOCK'SEAT	1
57	PMZ150-5N-D-057	支架	BRACKET,CABLE,SEAT	1

58	PMZ150-5N-D-058	网格	RR. VENTLLATION COVER	1
59	PMZ150-5N-D-059	螺栓	CRISSCROSS BULT M6*30	1
60	PMZ150-5N-D-060	螺栓	LOCK NUT M6	1
61	PMZ150-5N-D-061	支架	BRACKET, TAILLIGHT I	1
62	PMZ150-5N-D-062	尾灯	TAILLIGHT	1
63	PMZ150-5N-D-063	螺栓	CRISSCROSS BULT M6*16	1
64	PMZ150-5N-D-064	尾灯支架	BRACKET, TAILLIGHT II	1
65	PMZ150-5N-D-065	牌照支架	BRACKET, RR. LICENSE	1
66	PMZ150-5N-D-066	灯泡	BULB, RR. BTAKE LIGHT	1
67	PMZ150-5N-D-067	刹车灯	RR. BRAKE LIGHT	1
68	PMZ150-5N-D-068	反射器支架	SCREW TAPPING, ST3.0*40	1
69	PMZ150-5N-D-069	后装饰板	LOWER, RR. DECORATIVE BAR	1
70	PMZ150-5N-D-070	后下装饰板	VPPER, RR. DECORATIVE BAR	1
71	PMZ150-5N-D-071	转向灯	R. RR. TURNING LIGHT	1
72	PMZ150-5N-D-072	螺栓	SCREW TAPPING ,ST4.0*8	1
73	PMZ150-5N-D-073	转向灯	L. RR. TURNING LIGHT	1
74	PMZ150-5N-D-074	螺栓	NUT M10	1
75	PMZ150-5N-D-075	灯泡	BULB, TURNING LIGHT 12V3W	1
76	PMZ150-5N-D-076	反射镜片	COVER, RR. RURNING LIGHT	1
77	PMZ150-5N-D-077	后扶手	R. RR. HANDLE	1
78	PMZ150-5N-D-078	后扶手	L. RR. HANDLE	1
79	PMZ150-5N-D-079	靠背	BACKREST	1
80	PMZ150-5N-D-080	后货架	REAR TAILSTOCK	1
81	PMZ150-5N-D-081	后泥板上部	fender	1
82	PMZ150-5N-D-082	后泥板	RR. FENDER	1

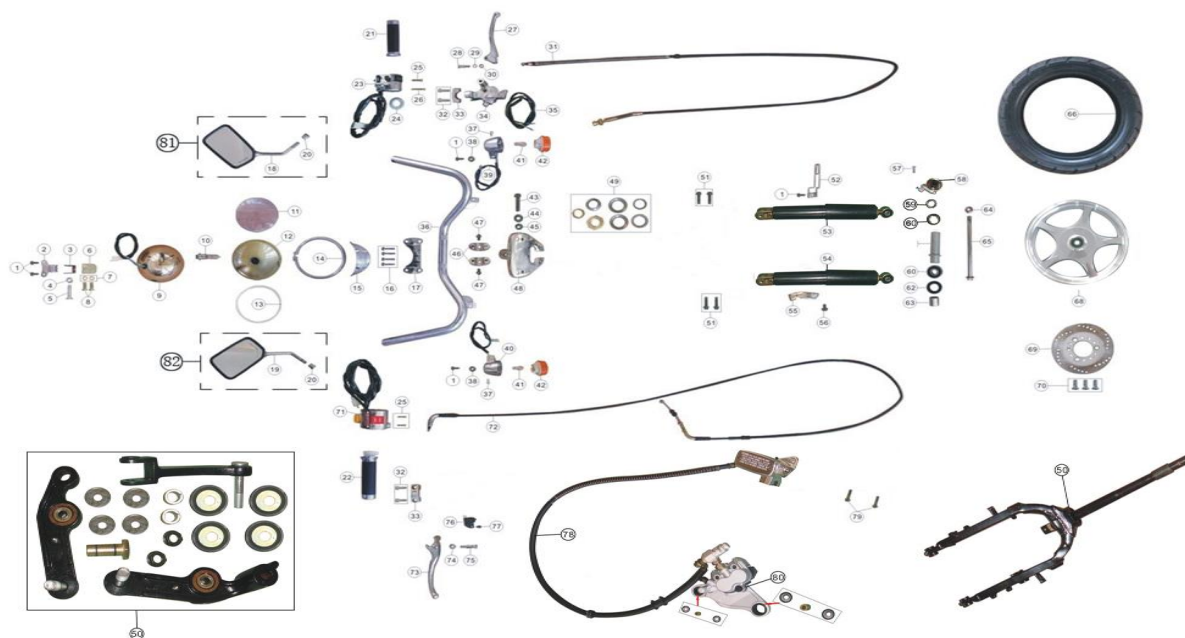

1	PMZ150-5N-E-001	螺栓	HEX FLANGEV BULT M6*16	1
2	PMZ150-5N-E-002	大灯支架	BRACKET, HEAD LIGHT I	1
3	PMZ150-5N-E-003	大灯支架	BRACKET, HEAD LIGHT II	1
4	PMZ150-5N-E-004	螺栓	NUT, M8	1
5	PMZ150-5N-E-005	螺栓	BOLT, M8*40	1

6	PMZ150-5N-E-006	固定板	FIXTNG BOARD	1
7	PMZ150-5N-E-007	垫片	ELASTICITY GASKET	1
8	PMZ150-5N-E-008	螺栓	CRISS CROSS BUVIT M*16	1
9	PMZ150-5N-E-009	大灯	HEAD LIGHT	1
10	PMZ150-5N-E-010	灯泡	BULB,HEAD LIGHT 12V35W	1
11	PMZ150-5N-E-011	大灯玻璃	GLASS,HEAD LIGHT	1
12	PMZ150-5N-E-012	大灯碗	REFLECTOR,HEAD LIGHT	1
13	PMZ150-5N-E-013	大灯圈	RVBBER GASKET	1
14	PMZ150-5N-E-014	大灯圈	FASTENER, HEAD LIGHT	1
15	PMZ150-5N-E-015	灯眉	CAP,HEAD LIGHT	1
16	PMZ150-5N-E-016	螺栓	HEX FLANGE BULT M8*38	1
17	PMZ150-5N-E-017	手把固定座下部	UPPER HOLDER,STEERING HANDLE	1
18	PMZ150-5N-E-018	后视镜	L.RR.MIRROR	1
19	PMZ150-5N-E-019	后视镜	R.RR.MIRROR	1
20	PMZ150-5N-E-020	螺栓	NUT ,RR.MIRROR	1
21	PMZ150-5N-E-021	左把手	L.HANDLE BAR	1
22	PMZ150-5N-E-022	油门胶套	THROOTLE GRIP	1
23	PMZ150-5N-E-023	左开关	L.SWITCH ASSY	1
24	PMZ150-5N-E-024	垫圈	RUBBE GASKET	1
25	PMZ150-5N-E-025	螺栓	CRISS CROSS BULT M5*22	1
26	PMZ150-5N-E-026	螺栓	CRISS CROSS BULT M5*35	1
27	PMZ150-5N-E-027	把手	L.BRAKE LEVER	1
28	PMZ150-5N-E-028	螺栓	BULT,L. HANDLEBAR M6*30	1
29	PMZ150-5N-E-029	支架	GASKET6	1
30	PMZ150-5N-E-030	螺栓	NUT M6	1
31	PMZ150-5N-E-031	刹车线	RR.BRAKE CABLE	1
32	PMZ150-5N-E-032	螺栓	HEX BULT M6*20	1
33	PMZ150-5N-E-033	刹车固定座	HOLDER. RR. BRAKE	1
34	PMZ150-5N-E-034	刹车固定座	RACKET, RR. BRAKE	1
35	PMZ150-5N-E-035	刹车开关	SWITCH, REAR BRAKE	1
36	PMZ150-5N-E-036	手把固定座下部	STEERING HANDLE	1
37	PMZ150-5N-E-037	螺栓	SCREW,TAPPING ST3.8*8	1
38	PMZ150-5N-E-038	螺栓	HEX FLANGE BLT M6	1
39	PMZ150-5N-E-039	转向灯	L. FR. TVRNINGLIGHT	1
40	PMZ150-5N-E-040	转向灯	R. FR. TVRNINGLIGHT	1
41	PMZ150-5N-E-041	灯泡	BULB,TVRNING LIGHT 12V10W	1
42	PMZ150-5N-E-042	转向灯灯罩	COVER, FRTVRNING LIGHT	1
43	PMZ150-5N-E-043	螺栓	HEX FLANGE BULT M10*50	1
44	PMZ150-5N-E-044	垫片	CONCAVE BUSH	1
45	PMZ150-5N-E-045	螺栓	LOCK NUT M10	1
46	PMZ150-5N-E-046	把手座	LOWERHOLDER,STEERING HANDLE	1
47	PMZ150-5N-E-047	螺栓	HEX FLANGE BULT M8*12	1
48	PMZ150-5N-E-048	把手座	BRACKET,STEERING HANDLE	1
49	PMZ150-5N-E-049	钢碗	7 DICES SET	1
50	PMZ150-5N-E-050	下联板	STEERING ASSY	1
51	PMZ150-5N-E-051	螺栓	HEX FLANGE BULT M8*40	1
52	PMZ150-5N-E-052	线卡	BRACKET, SPEED CABLE	1
53	PMZ150-5N-E-053	减震	L. FR. SHOCK ABSORBER	1

54	PMZ150-5N-E-054	减震	R. FR. SHOCK ABSORBER	1
55	PMZ150-5N-E-055	线夹	CLIP, FR. BRAKE TUBE	1
56	PMZ150-5N-E-056	螺栓	HEX FLANGE BULT M6*12	1
57	PMZ150-5N-E-057	螺栓	BULT, COUNTER	1
58	PMZ150-5N-E-058	转速器	COUNTER	1
59	PMZ150-5N-E-059	油封	SEAL GASKET I	1
60	PMZ150-5N-E-060	油封	BEARINGS 6201	1
61	PMZ150-5N-E-061	油封	SPACER, AXLE, FR. WHEEL	1
62	PMZ150-5N-E-062	油封	SEAL GASKER II	1
63	PMZ150-5N-E-063	衬套	SPACER, FR. WHEEL	1
64	PMZ150-5N-E-064	螺栓	LOCK NUT M12	1
65	PMZ150-5N-E-065	前轮轴	AXLE, FR. WHEEL 12*220	1
66	PMZ150-5N-E-066	轮胎	FRONT TYRE 12/70-20	1
67	PMZ150-5N-E-067	气门嘴	AIR VALVE	1
68	PMZ150-5N-E-068	前轮钢圈	FRONT RTM	1
69	PMZ150-5N-E-069	前碟刹盘	FRONT BRAKE DISK	1
70	PMZ150-5N-E-070	螺栓	BULT, FR. BRAKE DISK M8*25	1
71	PMZ150-5N-E-071	右开关	R. SWITCH ASSY	1
72	PMZ150-5N-E-072	油门线	THROTTLE CABLE	1
73	PMZ150-5N-E-073	刹车手柄	R. BRAKE LEVER	1
74	PMZ150-5N-E-074	螺栓	LOCK NUT M6	1
75	PMZ150-5N-E-075	螺栓	BULT, R. BRAKE LEVER M6*35	1
76	PMZ150-5N-E-076	右开关	SWITCH, R. BRAKE	1
77	PMZ150-5N-E-077	螺栓	BULT, SWITCH, FR. BRAKE	1
78	PMZ150-5N-E-078	前碟刹	FRHYDRAULIC BRAKE ASSY	1
79	PMZ150-5N-E-079	螺栓	HEX FLANGE BULT M8*30	1
80	PMZ150-5N-E-080	前碟刹下泵	BRAKE SHOE, FR. HYDRAULIC BAKE	1

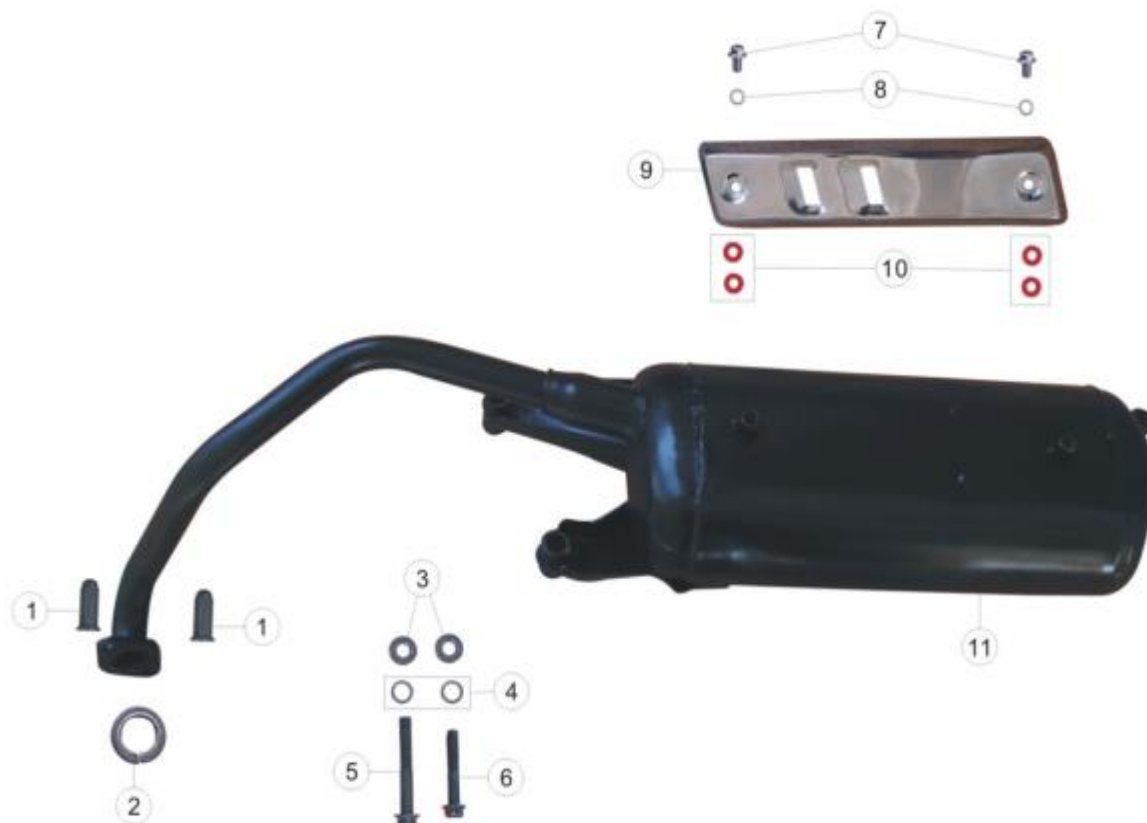

序	PMZ150-5N-F-001	零件名	零件描述	数量
2	PMZ150-5N-F-002	垫圈	MUFFLER GASKET	1
3	PMZ150-5N-F-003	螺帽	GASKET Φ8	1
4	PMZ150-5N-F-004	垫片	ELASTICITY GASKET Φ8	1
5	PMZ150-5N-F-005	螺栓	HEX FLANGE BULT M8*60	1
6	PMZ150-5N-F-006	螺栓	HEX FLANGE BULT M*50	1
7	PMZ150-5N-F-007	螺栓	HEX FLANGE BULT M6*10	1
8	PMZ150-5N-F-008	垫片	ELASTICITY GASKET Φ6	1
9	PMZ150-5N-F-009	装饰罩	DECORATIVE BOARD MVFFLER	1
10	PMZ150-5N-F-010	螺栓	ASBESTOS GASKET Φ6	1
11	PMZ150-5N-F-011	消音器	MUFFLER	1